

GUTMANN EF68



Ausschreibungstexte
finden Sie auch unter
www.ausschreiben.de

07.2012





Makkah Royal Clock Tower, Mekka, Saudi-Arabien | DAR AL Handasah Architects | Makkah Royal Clock Tower, Makkah, Saudi Arabia

Anspruch trifft Wirtschaftlichkeit

Elementfassaden werden überwiegend bei Großobjekten mit extrem kurzen Bauzeiten und bei hohen Gebäuden, die ohne Gerüst montiert werden, eingesetzt. Der Vorteil der Elementfassade EF68 liegt auf der Hand: Ein hoher Vorfertigungsgrad spart Zeit und Geld. Die einzelnen Fassadenelemente werden im Werk des Metallbauers komplett gefertigt und vormontiert, einschließlich aller Füllungen sowie Isolierglas, Paneele, Öffnungselemente oder Sonnenschutzmodulen.

High standards meet cost-effectiveness

Element curtain walls are most commonly used for large construction sites with extremely short construction times as well as for tall buildings erected without scaffolding. The advantage of the element curtain wall EF68 is obvious. A high degree of prefabrication saves time and money. The individual curtain wall elements are all fabricated and preassembled at the metal manufacturing plant, including fillings, such as sound-control glass, panels, opening elements, and sun protection modules.



Die Energiewerte finden Sie im Kapitel 2 dieses Ordners.
Please find the energy values in chapter 2.

Pfosten senkrecht (Fuge 10 mm, PA - Steg 34 mm) /
Mullion, Vertical (gap 10 mm, PA bridge 34 mm)

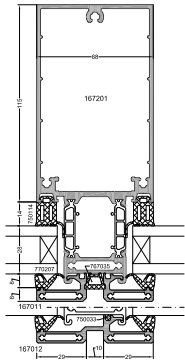
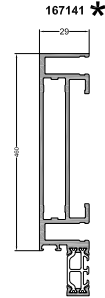
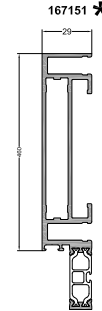
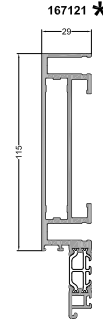
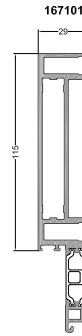
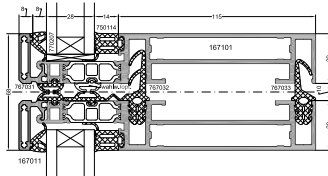
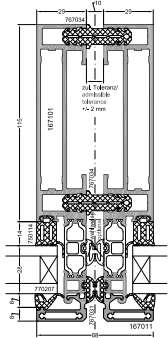

Alternativ durchgängige
Glasleiste 167012 für
senkrechten und waag-
rechten Einsatz möglich

Continuous glass bead
167012 optionally
available for vertical and
horizontal use

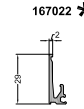
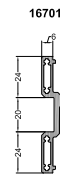
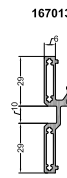
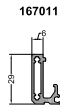
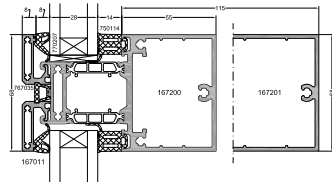
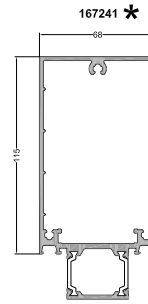
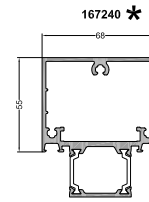
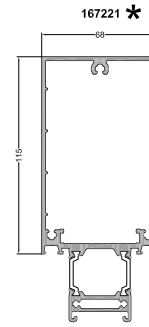
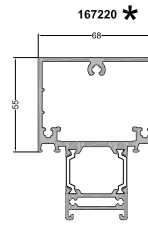
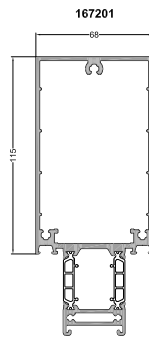
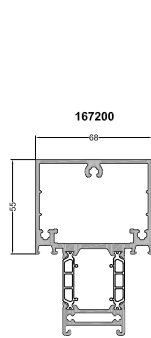

Pfosten/
Mullion

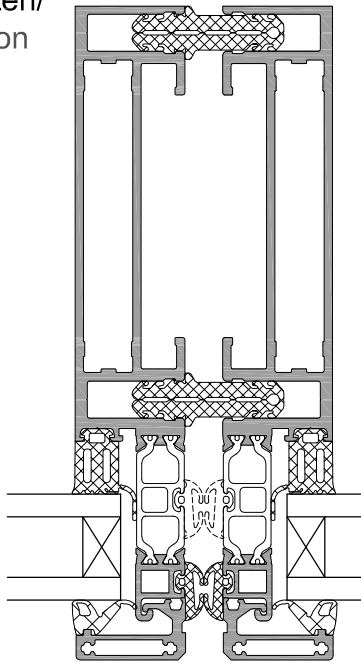

Riegel, waagrecht/
Transom, horizontal

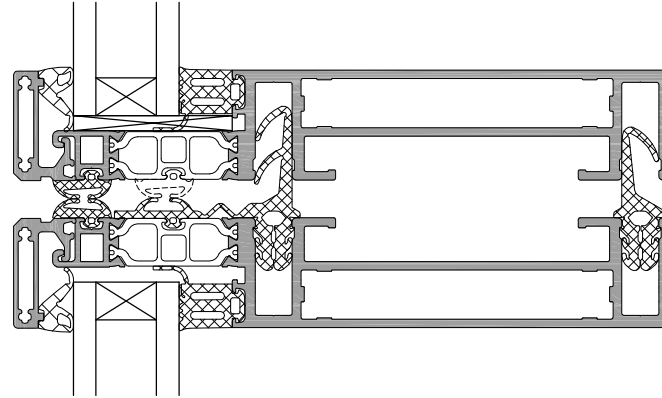

Konstruktionsvorteile:

- Elementfassade thermisch getrennt mit umlaufend filigranen Ansichtsbreiten von nur 68 mm
- Variable Gestaltung von außen
 - Rahmenoptik mit umlaufender Glasleiste
 - Optische SG-Fassade
 - SG - Fassade
 - Stoßfugen mit 10 mm und 20 mm
- Hoher Vorfertigungsgrad mit geringen Montagekosten
- Rationelle Fertigung durch Eckverbindung auf Gehrung
- Elementabmessungen und Füllgewichte
max. Größe B x H 2600 x 3600 mm
max. Füllgewichte 300 kg
- Überlappendes Dichtsystem durch Stoßdichtung
- Systemlösungen für Außen- und Innenecken in Ganzglasoptik
- Wahlweise Gliederung der Elemente durch senkrechte und waagrechte Sprossen
- Fassaden-Befestigungskonsolen geprüft als Systemlösung
- Sonnenschutzbolzen zur Befestigung der Sonnenschutzsysteme auf der Außenseite
- Glasdicken:
 - Isolierglas von 26 bis 38 mm
- Einselelemente wahlweise
 - Fenster Serie S70 (DK / D / K)
 - Senkklapp in SG-Optik

Design Advantages:

- Element curtain wall, thermally insulated, with a graceful all-around profile view width of only 68 mm
- Variable exterior design
 - Frame design with glazing bead all-around
 - Simulated safety-glass curtain wall
 - Safety-glass curtain wall
 - Butt joint optionally 10 mm or 20 mm
- High degree of prefabrication, for low assembly costs
- Economical manufacture due to mitered corner connections
- Element widths and filling weights:
max. width and height: 2600 x 3600
max. glass weight: 300 kg
- Overlapping sealing system, with special vertical and horizontal butt-joint gaskets
- System solutions for outer and inner corners in all-glass design
- Optional structuring of elements with vertical and horizontal bars
- Curtain-wall mounting brackets certificated as system solution
- Sun-shade bolt available for installation of outside sun-shade systems
- Glass thickness:
 - Insulating glass, 26 to 38 mm
- Panel elements optional:
 - Window System S 70 (Tilt+Turn / Turn / Tilt)
 - Top-hung lowering windows in safety-glass design

Konstruktionsbeschreibung / Bidding Documents

Elementfassade EF 68

Profilserie zur Herstellung wärmegeämmter Fassadenkonstruktionen aus stranggepressten Aluminiumprofilen **System Gutmann EF 68** (Hermann Gutmann Werke AG)

Klassifizierung Einstufung:

U-Werte nach EN ISO 10077-2, $U_f = 1,9$ bis $2,5$ W/m²K je nach Profilgeometrie
 Systemprüfung für Vorhangfassaden nach Produktnorm DIN EN 13830: 2003-11
 Klassifizierung gem. Prüfbericht Nr. 07/10-A196-B1

Luftdurchlässigkeit: Klasse AE
 Schlagregendichtheit: Klasse RE 750
 Widerstand gegen Wind: ± 1350 Pa

Vorhangfassade aus wärmegeämmten Aluminiumprofilen, Isolierstege aus glasfaserverstärktem Polyamid. Profile für den Eigenverbund sind nicht zugelassen.
 Stoßfugen mit 10 mm oder 20 mm

Variable Profilgestaltung von außen:

- Rahmenoptik mit umlaufender Glasleiste
- Structural-Glazing Fassade oder optische SG-Fassade

Elementgrößen max.: BxH 2600 x 3600 mm

Füllgewichte max.: 300 kg

Grundkonstruktion

Wahlweise Gliederung der Elemente durch senkrechte und / oder waagrechte Sprossen, Rahmenprofile durch Eckverbindung auf Gehrung gefertigt. Die Stoßdichtungen sind als überlappendes Dichtsystem zur geschossweisen Entwässerung ausgeführt.

Fassaden-Befestigungskonsolen als statisch berechnete Systemlösung.

Glasdicken von 26 bis 38 mm.

Einsatzelemente wahlweise einsetzbar, Drehkipp / Dreh / Kipp / Klapp / Senkklapp

The EF 68 Element Curtain Wall

A profile series for the manufacture of insulated curtain-wall structures of extruded aluminum profiles, of the System Gutmann EF 68 (Hermann Gutmann Werke AG)

Classification Rating:

U values as per EN ISO 10077-2, $U_f = 1.9$ to 2.5 W/m²K, depending on profile geometry
 System test for curtain walls as per product standard DIN EN 13830: 2003-11
 Classification as per test report no. 07/10 A196-B1

Air permeability: Class AE
 Driving-rain resistance: Class RE 750
 Wind resistance: ± 1350 Pa

A curtain wall of insulated aluminum profiles, insulation pins of fiber-glass reinforced polyamide. Profiles for self-connection are not authorized. Butt joints 10 mm or 20 mm

Variable profile design from outside:

- frame view with circumferential glass strip
- structural-glazing curtain wall or visual SG curtain wall

Element sizes max.: WxH 2600 x 3600 mm

Net weights max.: 300 kg

Optional structure of elements by vertical and/or horizontal struts, frame profiles manufactured on miter by corner connection. The butt gaskets are provided as an overlapping gasket system for storey-by-storey drainage.

Curtain-wall attachment consoles as statically calculated systems solution.

Glass thicknesses of 26 to 38 mm

Panel element optional, T&T/turn tilt/lowering/top-hung lowering

Wärmeberechnung / Heat Calculation Uf - Werte / Uf Values

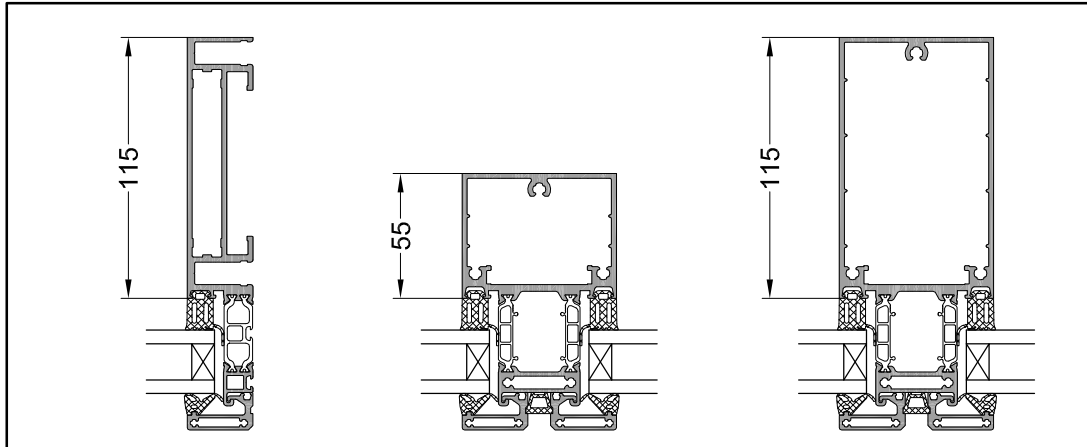

Isoliersteg/ Insulation bridge in mm	Füllstärke/ Filling thickness in mm	Rahmenprofil Mullion profile Uf-Wert/ Uf Values (W/m²K)	Sprosse 55 mm/ Crossbar 55 mm Uf-Wert/ Uf Values (W/m²K)	Sprosse 115 mm/ Crossbar 115 mm Uf-Wert/ Uf Values (W/m²K)
26 mm	24 - 29	3,33 - 3,09	2,62 - 2,40	2,74 - 2,51
	30 - 34	3,06 - 2,95	2,36 - 2,27	2,46 - 2,37
34 mm	26 - 29	2,51 - 2,41	2,10 - 2,02	2,17 - 2,09
	30 - 34	2,38 - 2,31	1,99 - 1,92	2,06 - 1,99
	35 - 40	2,30 - 2,28	1,90 - 1,87	1,97 - 1,94

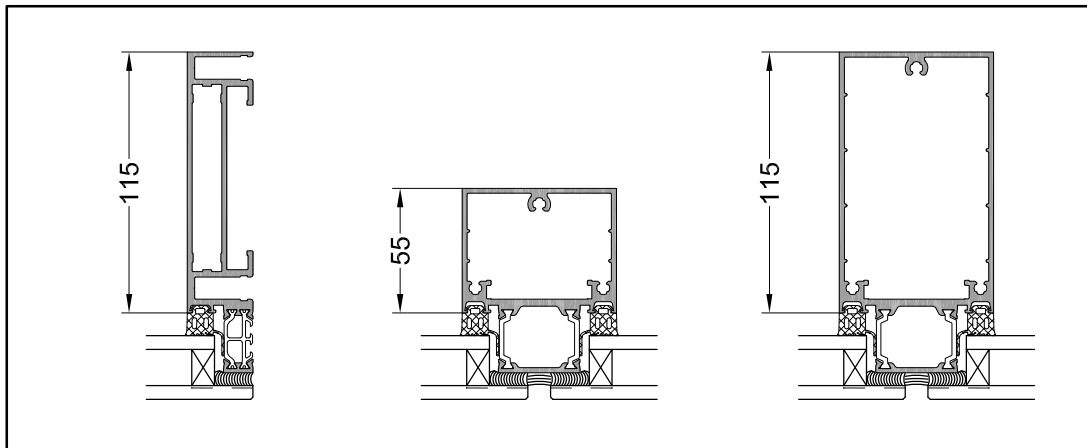

Isoliersteg/ Insulation bridge in mm	Füllstärke/ Filling thickness in mm	Rahmenprofil Mullion profile Uf-Wert/ Uf Values (W/m²K)	Sprosse 55 mm/ Crossbar 55 mm Uf-Wert/ Uf Values (W/m²K)	Sprosse 115 mm/ Crossbar 115 mm Uf-Wert/ Uf Values (W/m²K)
26 mm	24 - 29	2,83 - 2,58	2,31 - 2,10	2,39 - 2,18
	30 - 34	2,54 - 2,46	2,07 - 1,99	2,15 - 2,07

Eckverbindung / Elementgewichte
Corner Connection/
Element Weights

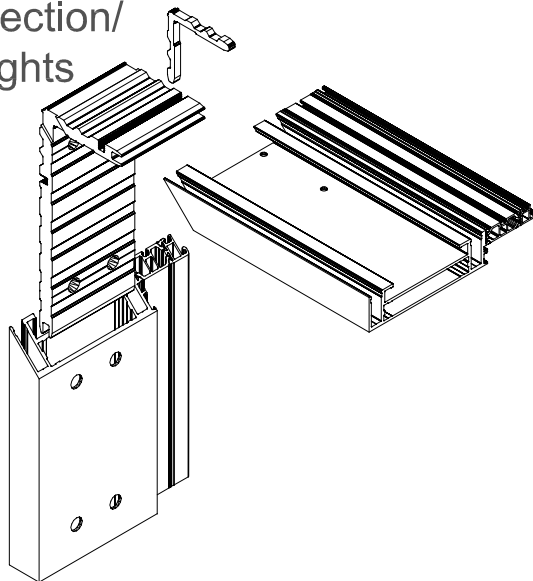

Umlaufender Rahmen/
All-around frame:

- Profile 45° Gehrung geschnitten/
Profile cut for 45° miter
- Eckwinkel stanzenbar und zum
verstiften/ Corner cleats to be
punched or pinned
- Abdichtung durch Verklebung/
Sealing by gluing

Einfachrastfeld/ Single-grid field

Doppelrastfeld/ Dual-grid field

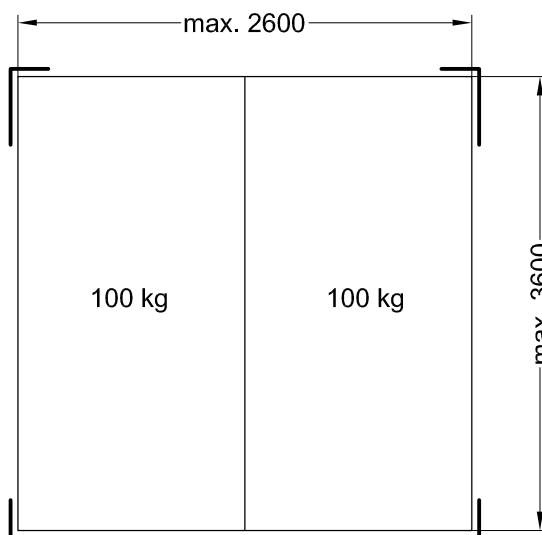
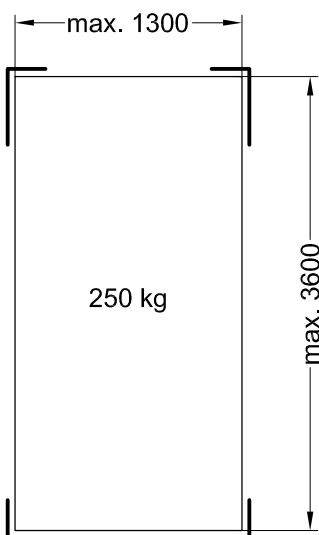

**Elementgewichte/
Element weights:**

max. Gewicht/
max. weight:
300 kg

**Rastergrößen/
Grid sizes:**

Einfachraster B x H/
Single grid, W x H:
max. 1300 x 3600 mm

Doppelraster B x H
Dual grid, W x H:
max. 2600 x 3600 mm

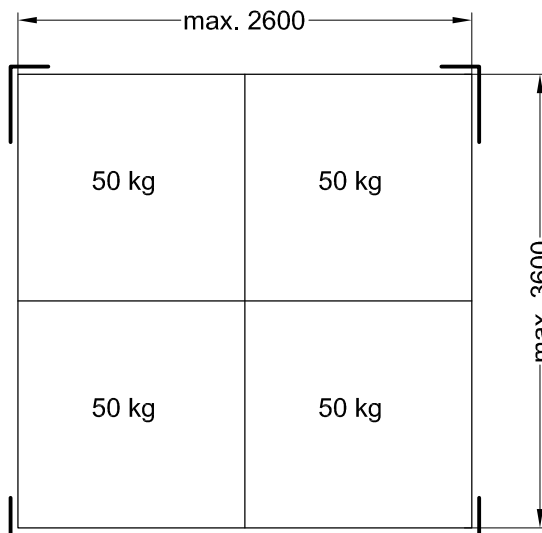
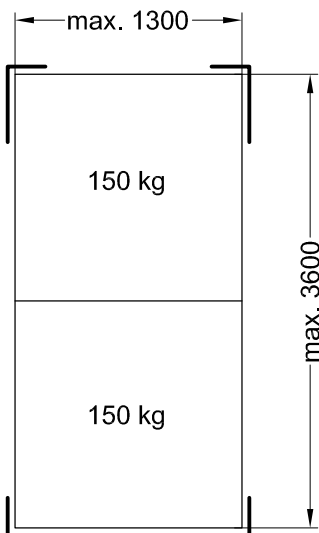

Anordnung Eckwinkel/
Arrangement of
corner cleats:

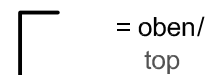

= oben/
top



= unten/
bottom

Stoßverbindungen / Joint Connections

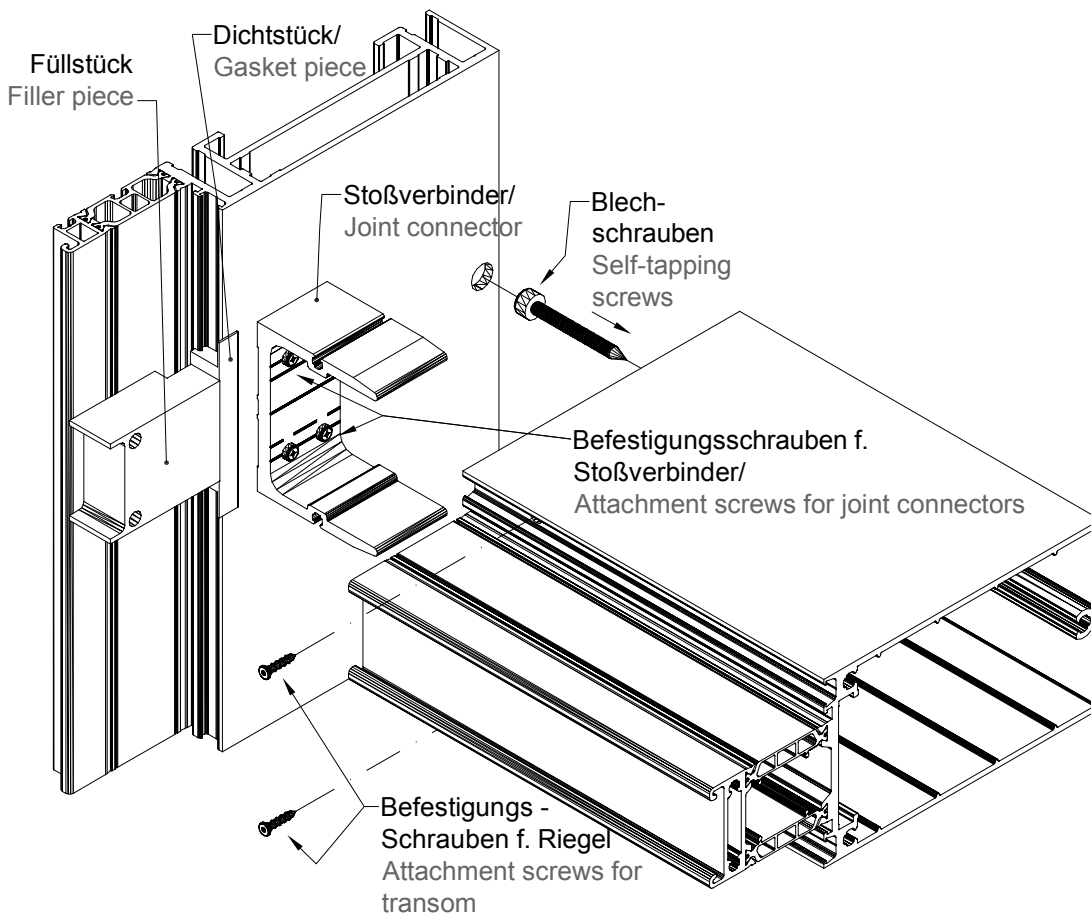
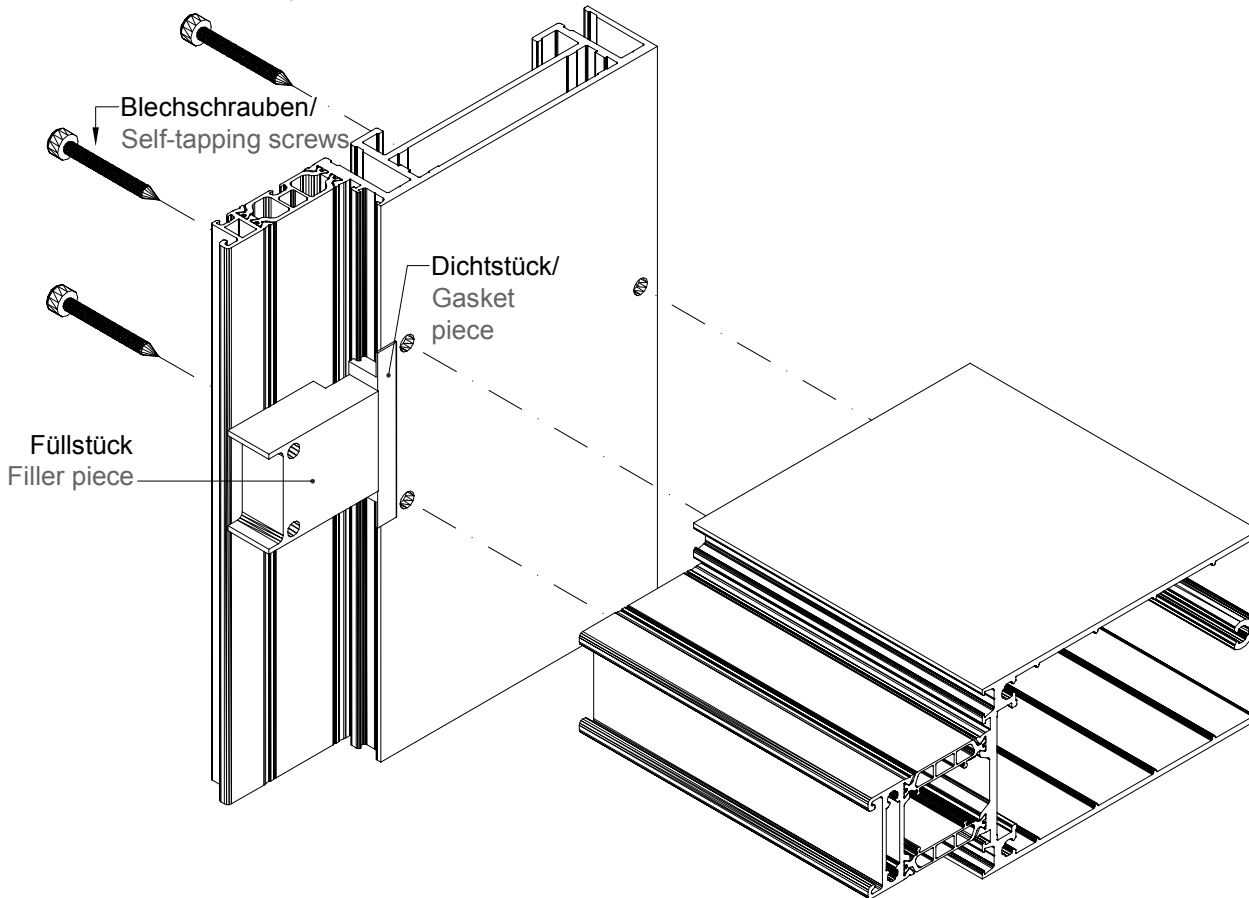

EF68
2

Pfosten senkrecht (Fuge 10 mm, PA - Steg 34 mm) /
Mullion, Vertical (gap 10 mm, PA bridge 34 mm)

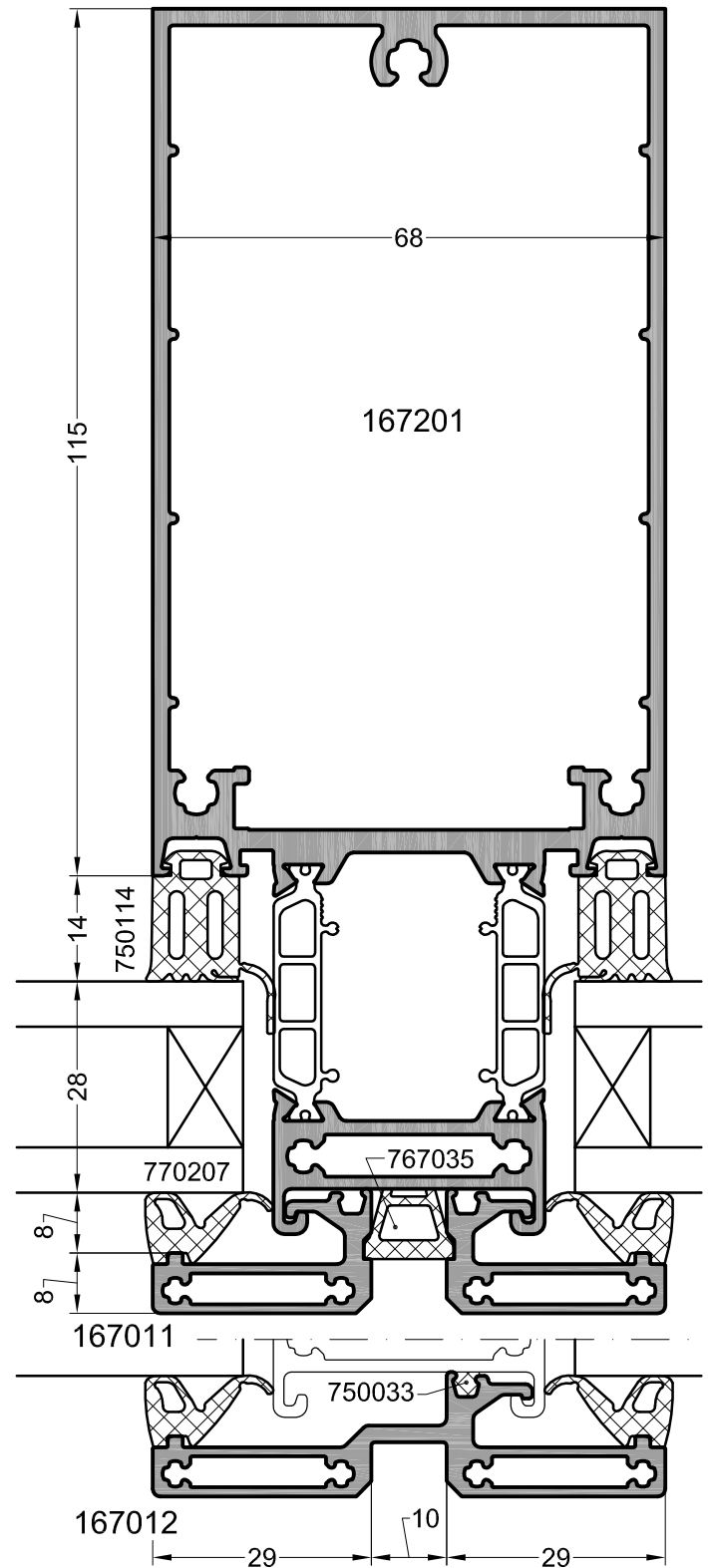
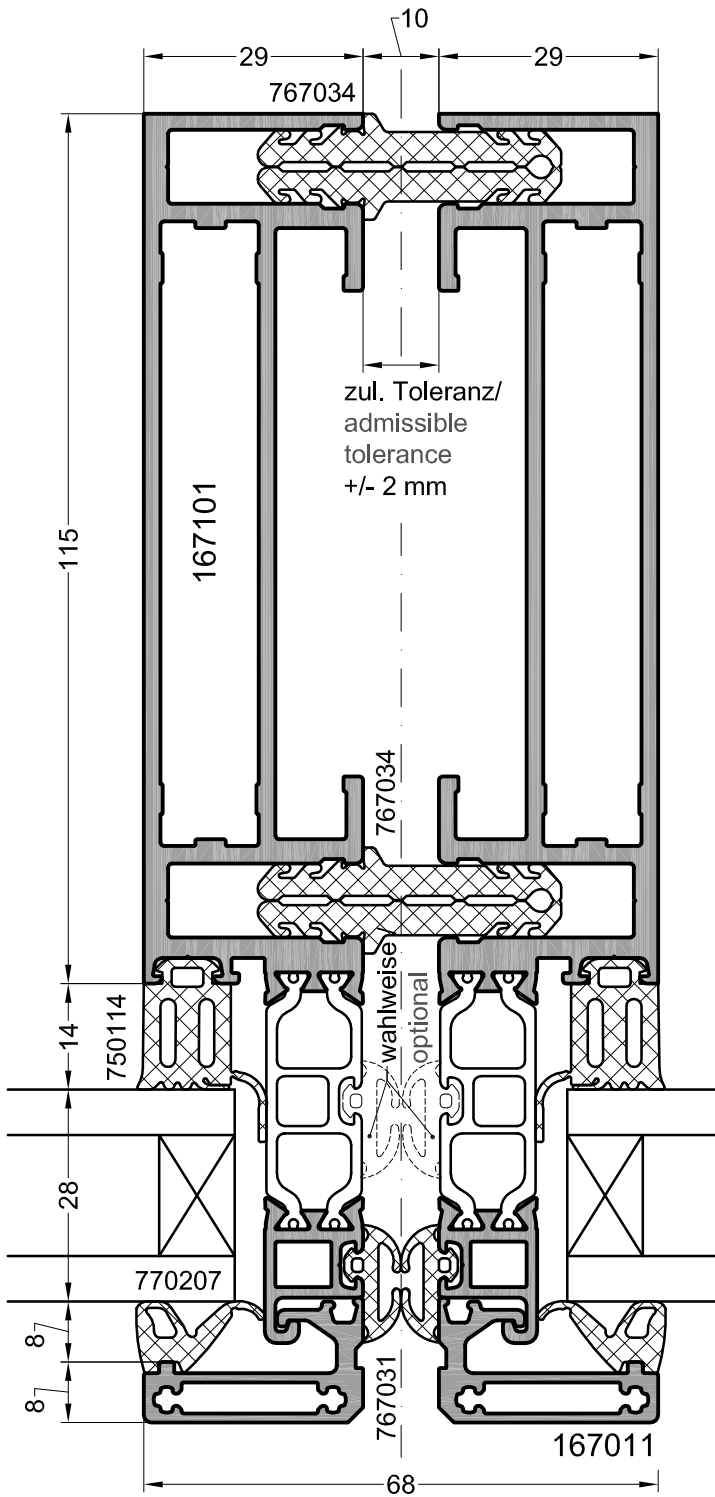
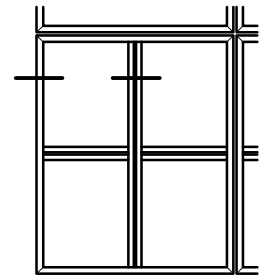

Riegel waagrecht (Fuge - 10 mm, PA - Steg 34 mm)
Transom, Horizontal (gap 10 mm, PA bridge 34 mm)

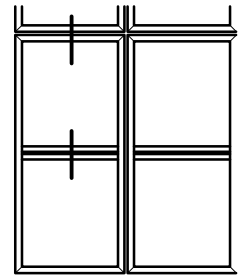

EF68
2

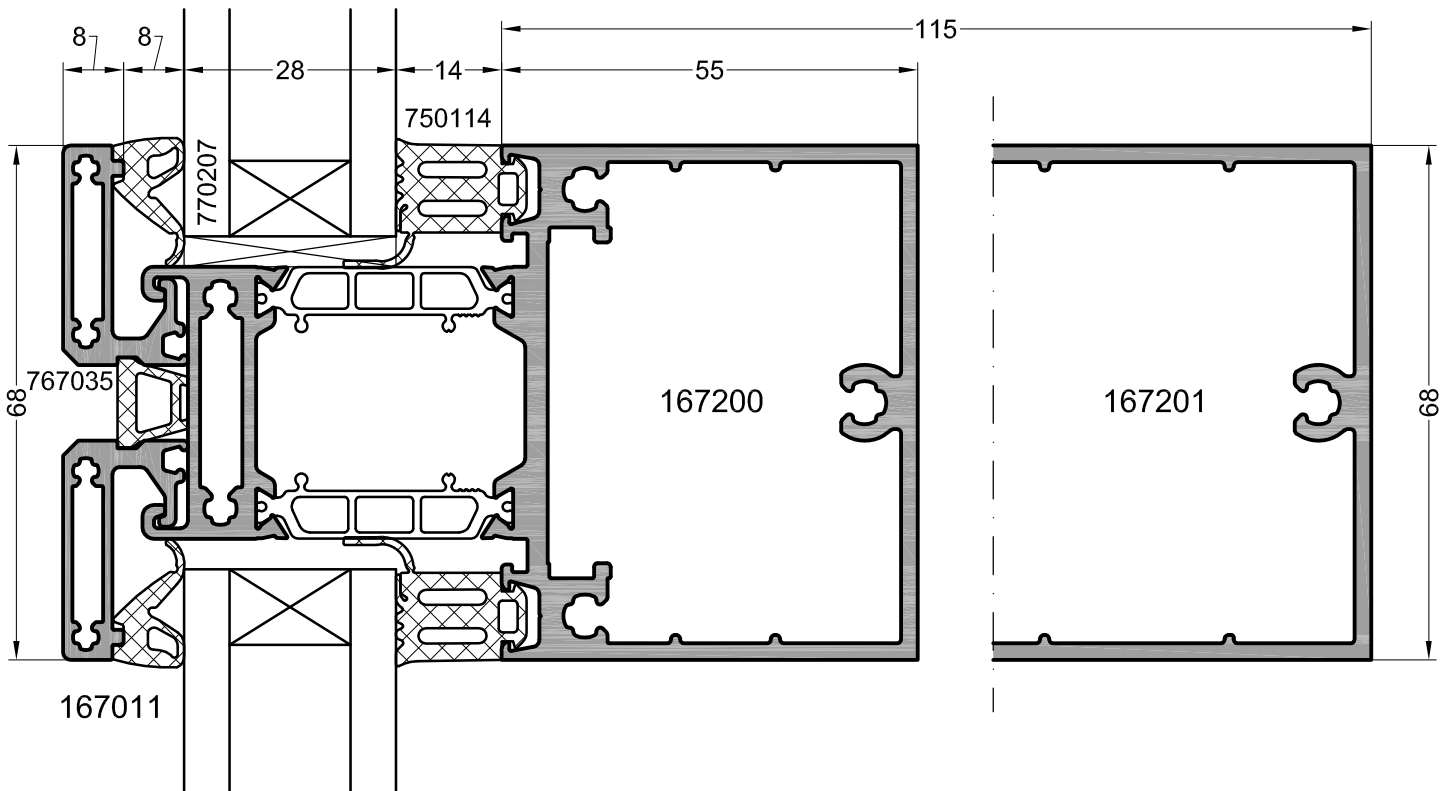
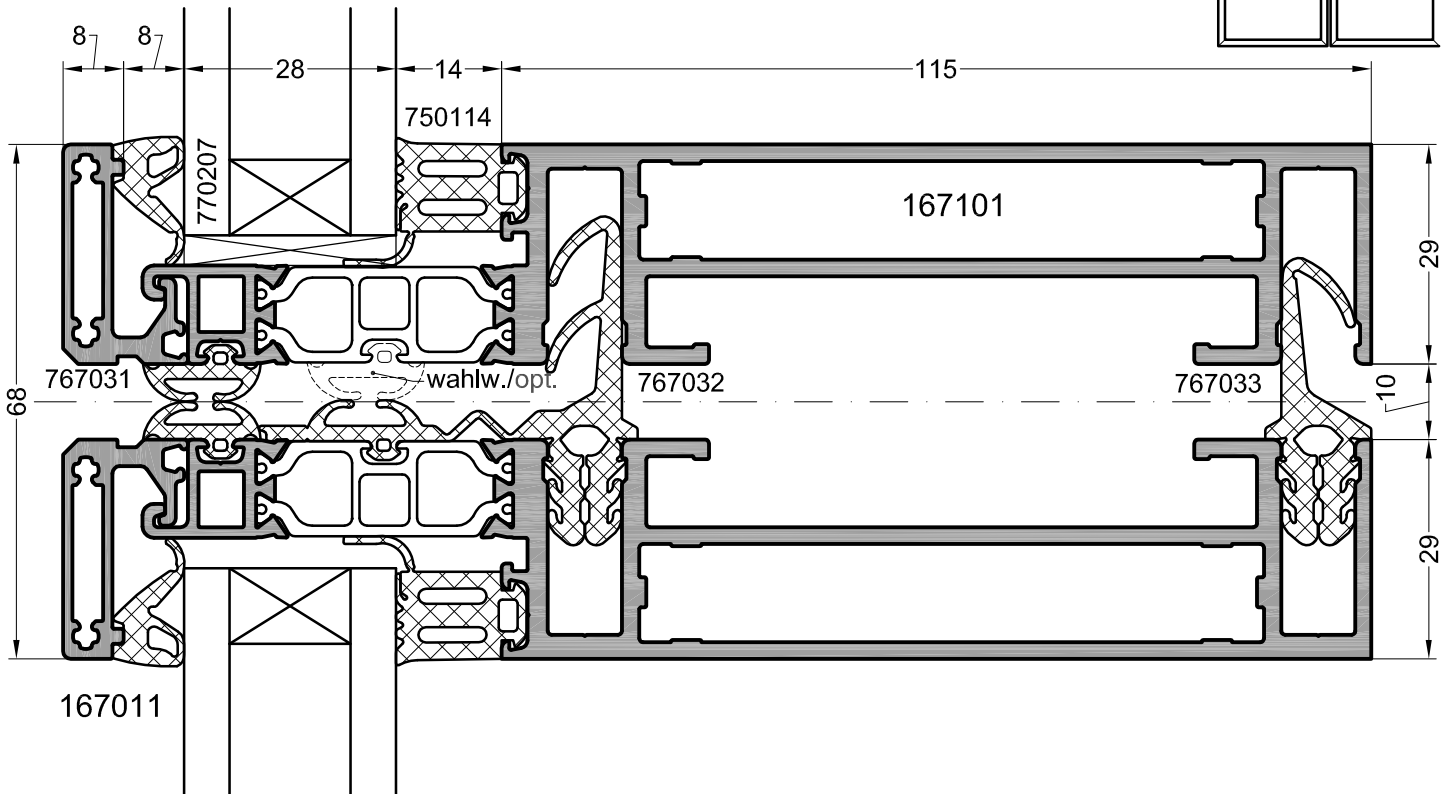

Pfosten senkrecht (Fuge - 20 mm, PA - Steg 34 mm)
Mullion, Vertical (gap 20 mm, PA bridge 34 mm)

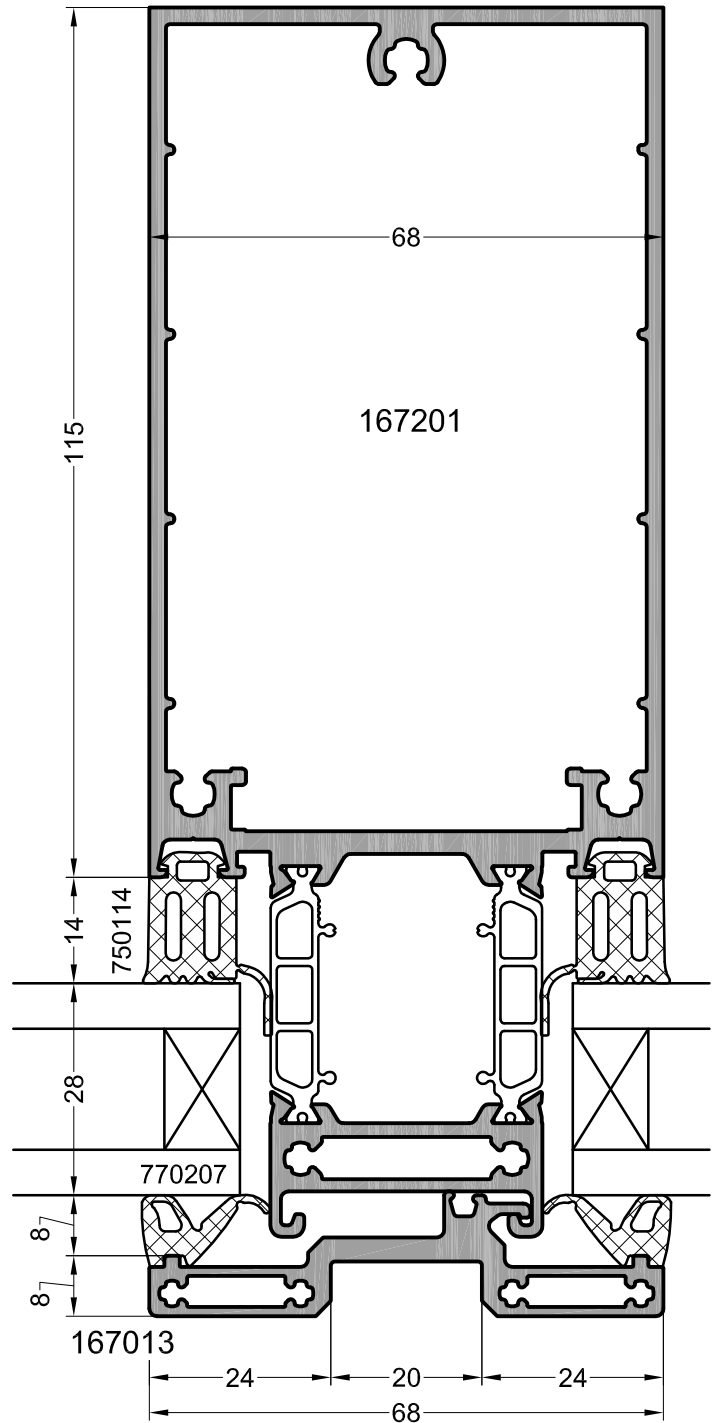
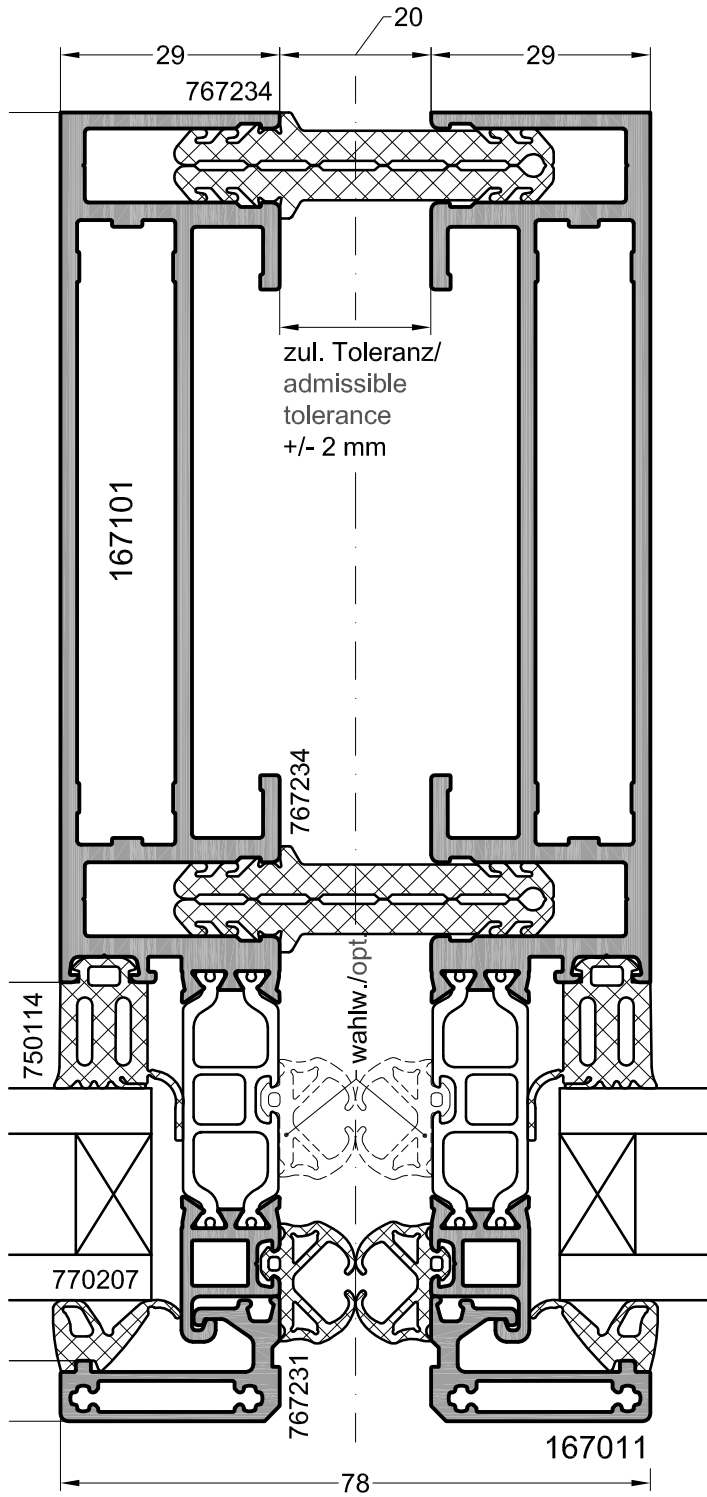
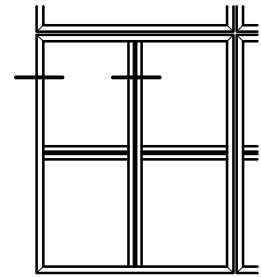

Riegel waagrecht (Fuge - 20 mm, PA - Steg 34 mm)/
Transom, horizontal (gap 20 mm, PA bridge 34 mm)

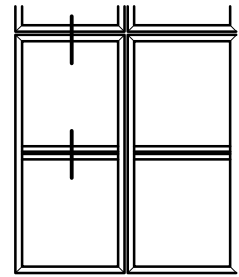

EF68
2

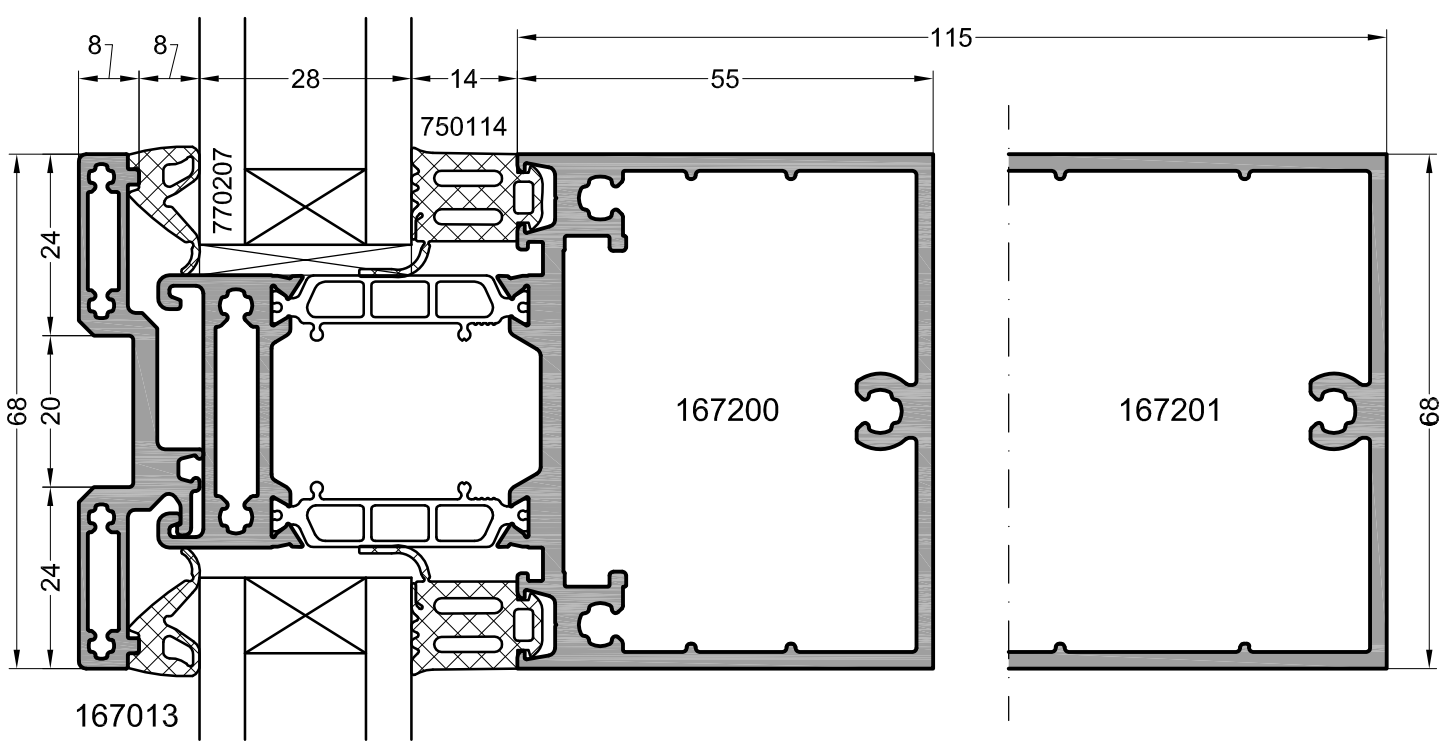
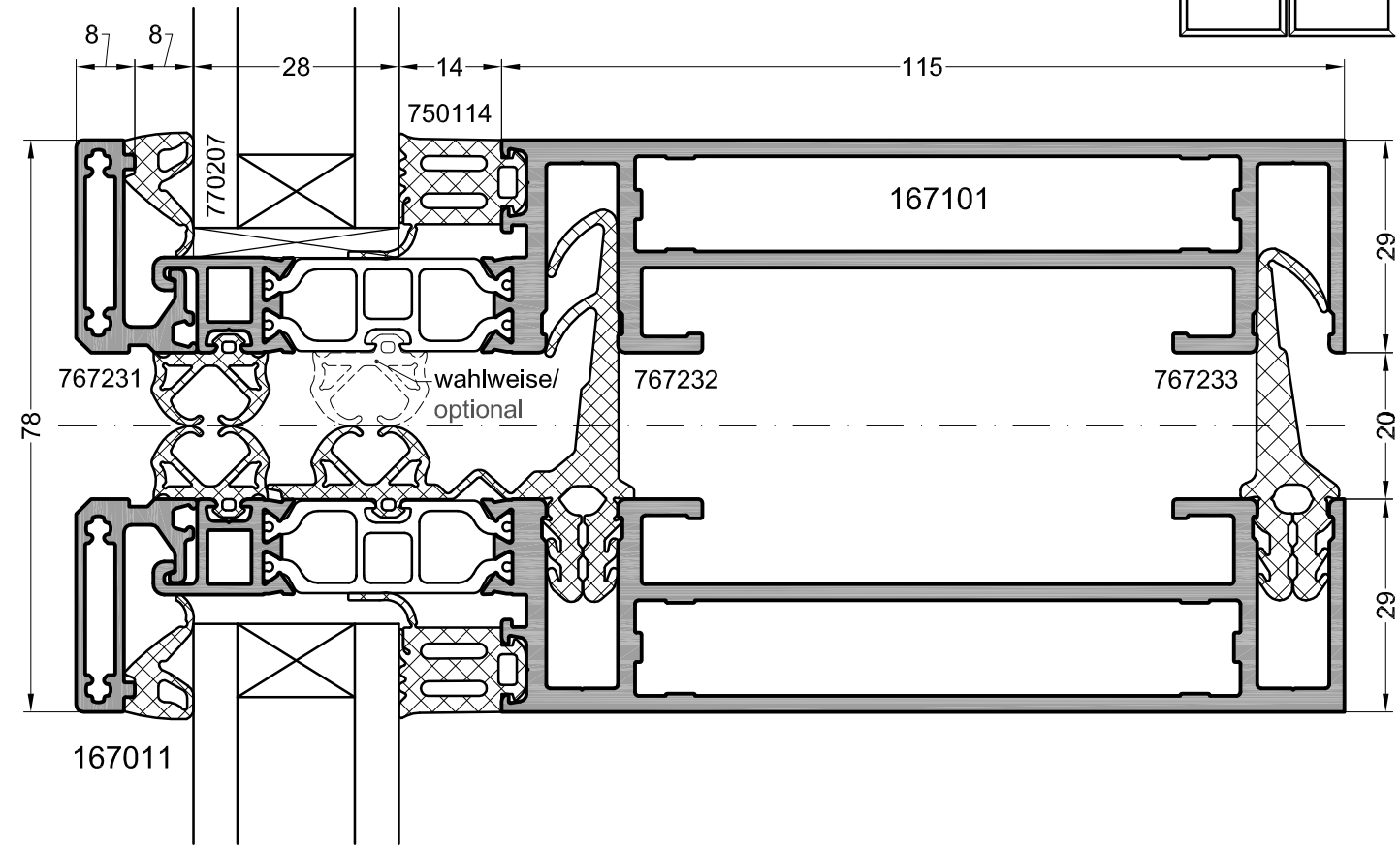

Semi SG - Fassade (Fuge 10 mm, PA - Steg 34 mm)
Semi-Safety-Glass Curtain Wall (gap 10 mm,
PA bridge 34 mm)

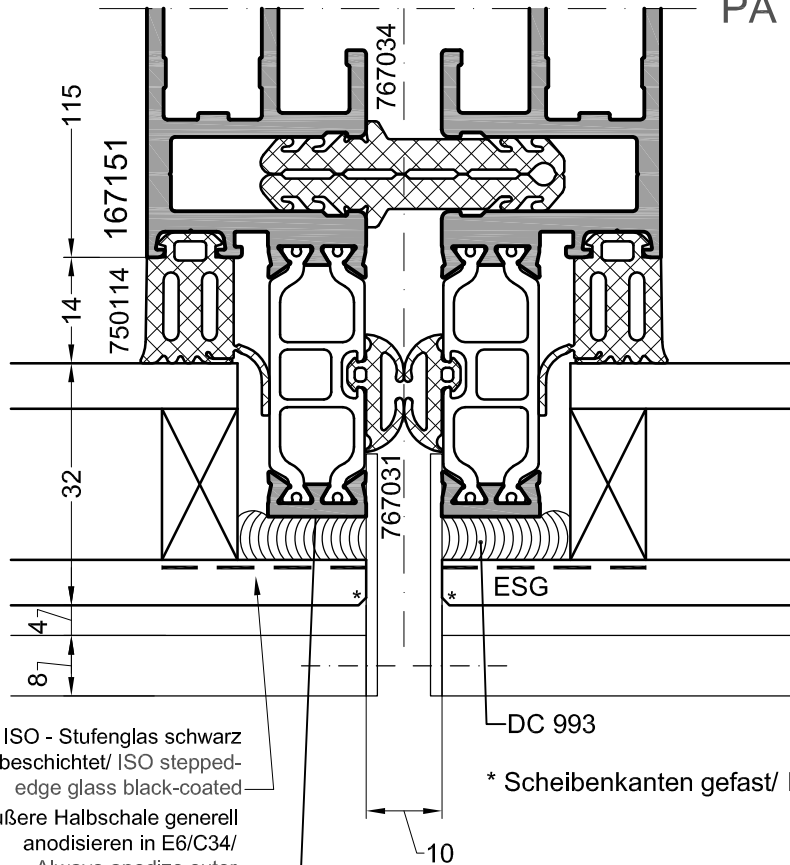
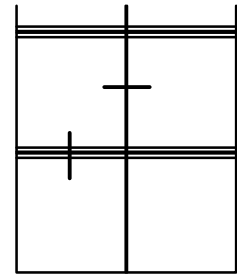

Achtung!
Scheibenrandverbund gegen UV-Strahlung widerstandsfähig ausführen. Glasdicken bzw. Scheibenrandausbildung ist mit dem Glaslieferanten abzustimmen.

Note!
Ensure that plate-edge lamination is resistant against UV radiation. Have glass supplier approve glass thicknesses and plate-edge conditions.

* Scheibenkanten gefast/ Plate edge camfered

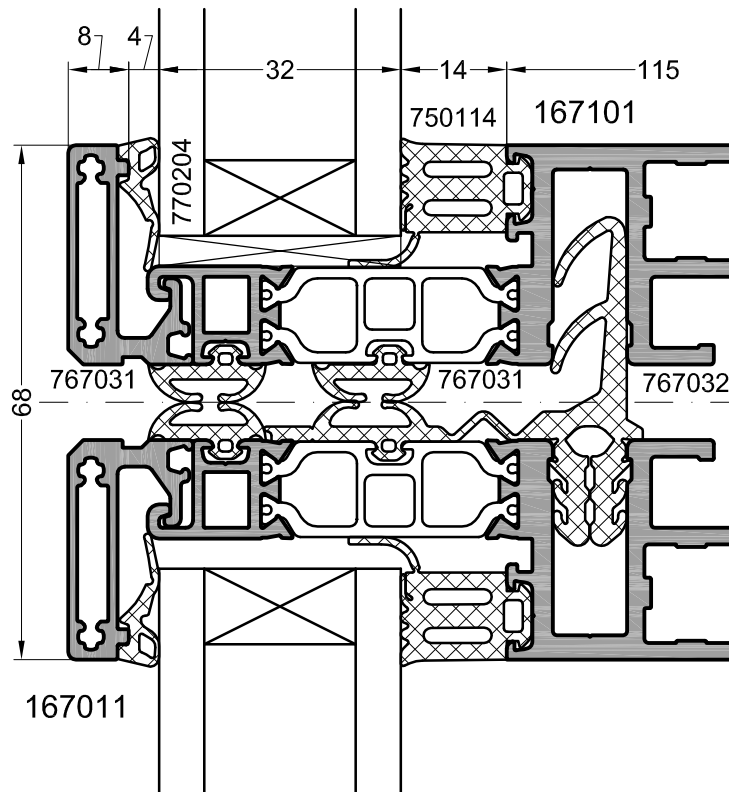

Semi SG - Fassade (Fuge 20 mm, PA - Steg 34 mm)/
Semi-Safety-Glass Curtain Wall
(gap 20 mm, PA bridge 34 mm)

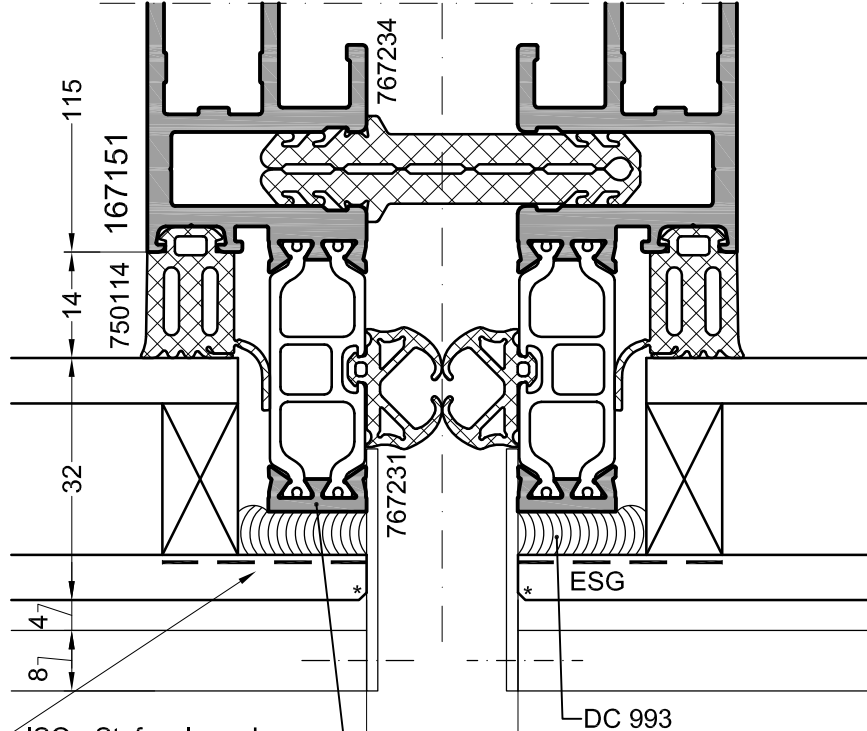
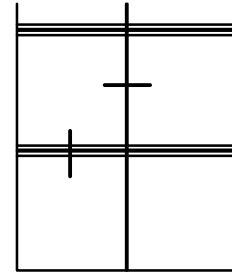

Achtung!
Scheibenrandverbund gegen UV-Strahlung widerstandsfähig ausführen. Glasdicken bzw. Scheibenrandausbildung ist mit dem Glaslieferanten abzustimmen.

Note!
Ensure that plate-edge lamination is resistant against UV radiation. Have glass supplier approve glass thicknesses and plate-edge conditions.

ISO - Stufenglas schwarz beschichtet/
ISO stepped-edge glass black-coated

Äußere Halbschale generell anodisieren in E6/C34/
Always anodize outer half-shell profile in E6/C34

* Scheibenkanten gefast/
Plate edge camphered

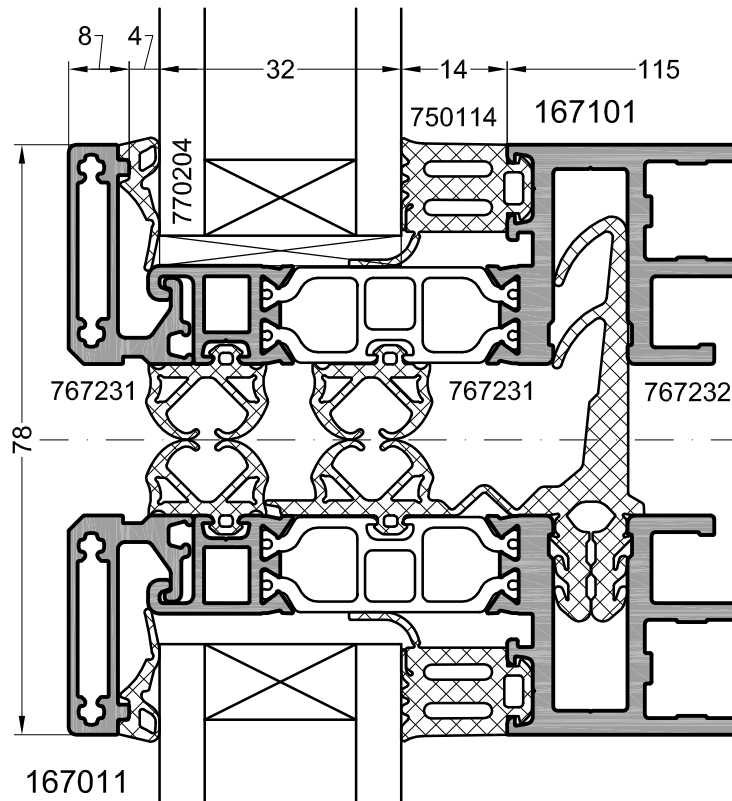

Pfosten senkrecht (Fuge - 10 mm, PA - Steg 26 mm)
Mullion, Vertical (gap 10 mm, PA bridge 26 mm)

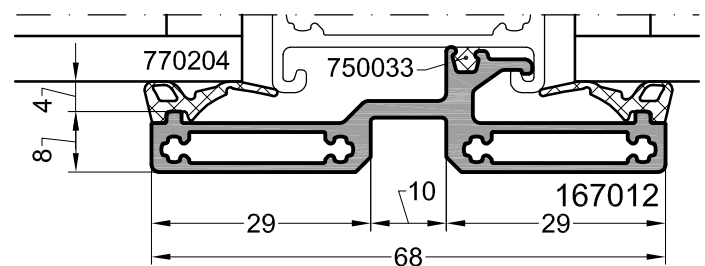
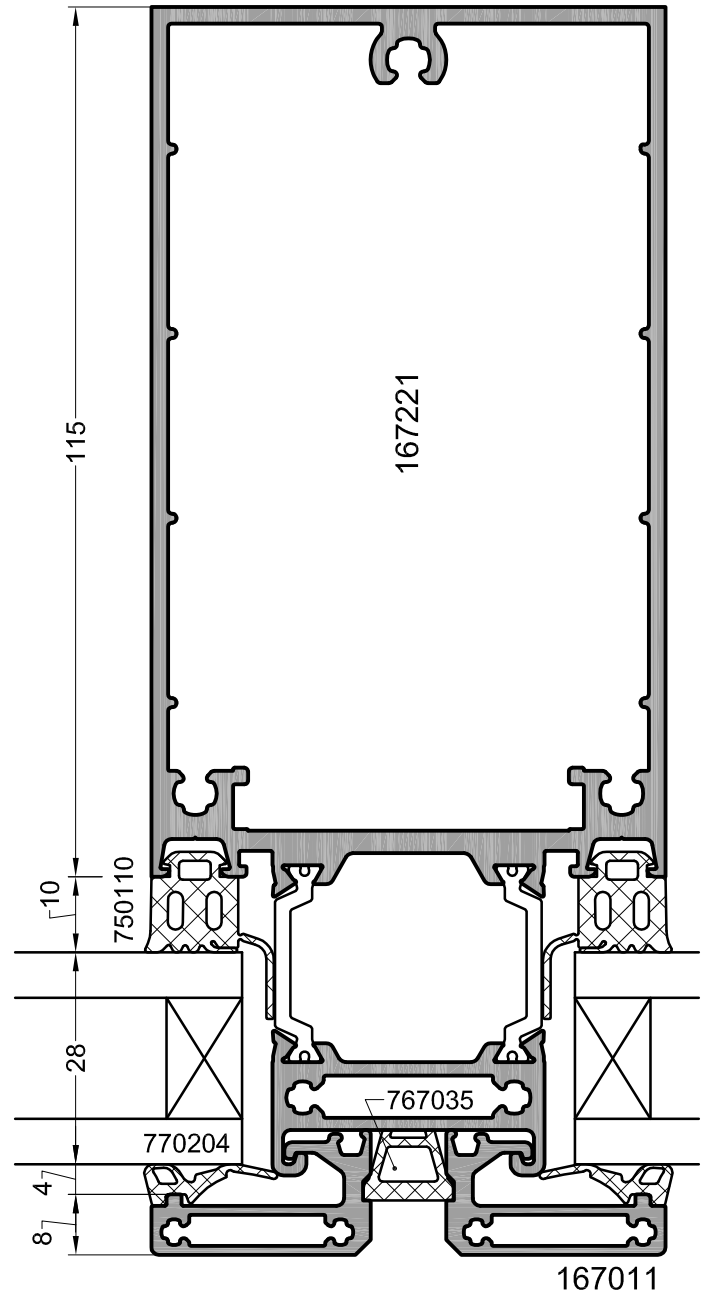
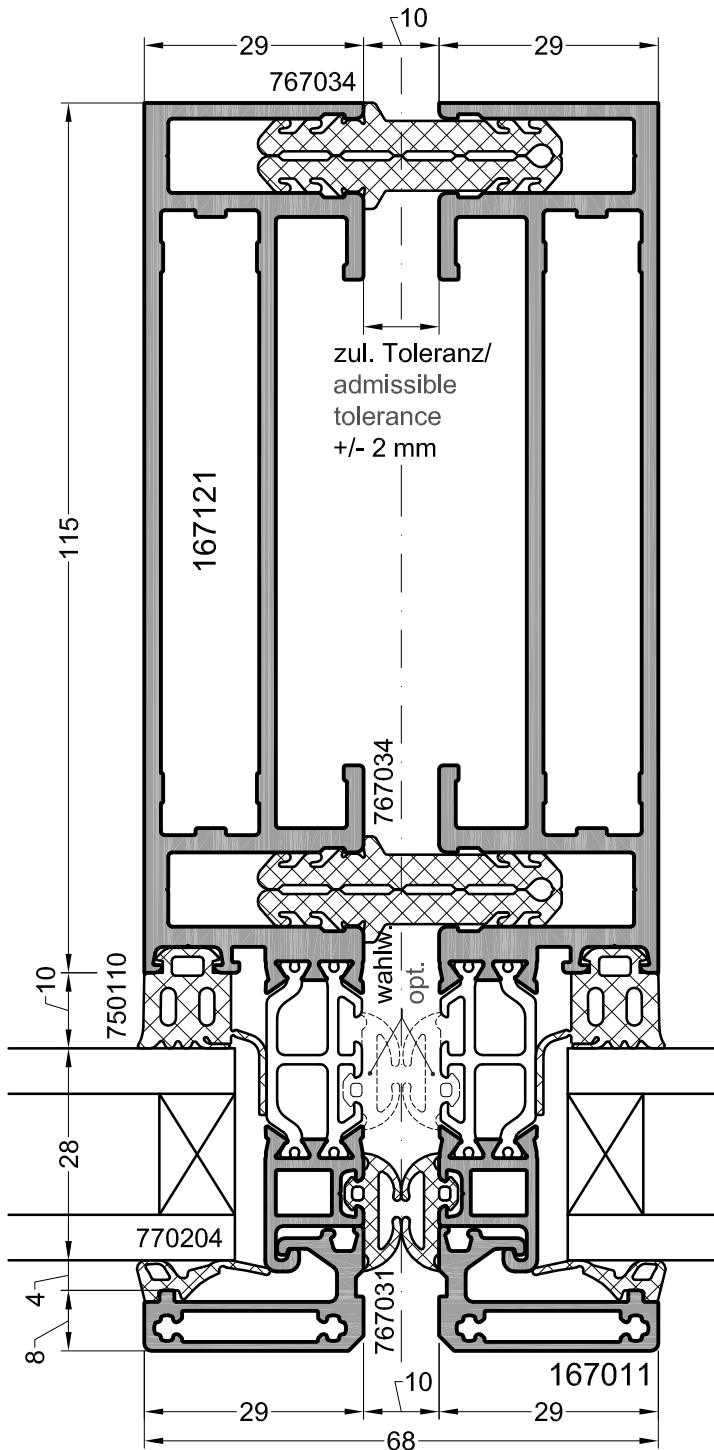
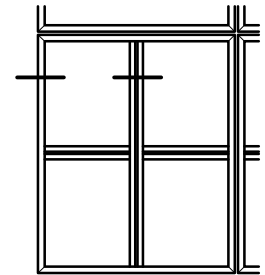

Riegel waagrecht (Fuge - 10 mm, PA - Steg 26 mm)/
Transom, horizontal (gap 10 mm, PA bridge 26 mm)

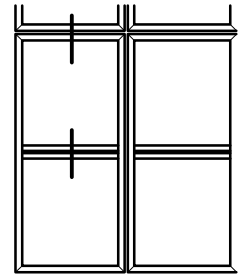

EF68
2

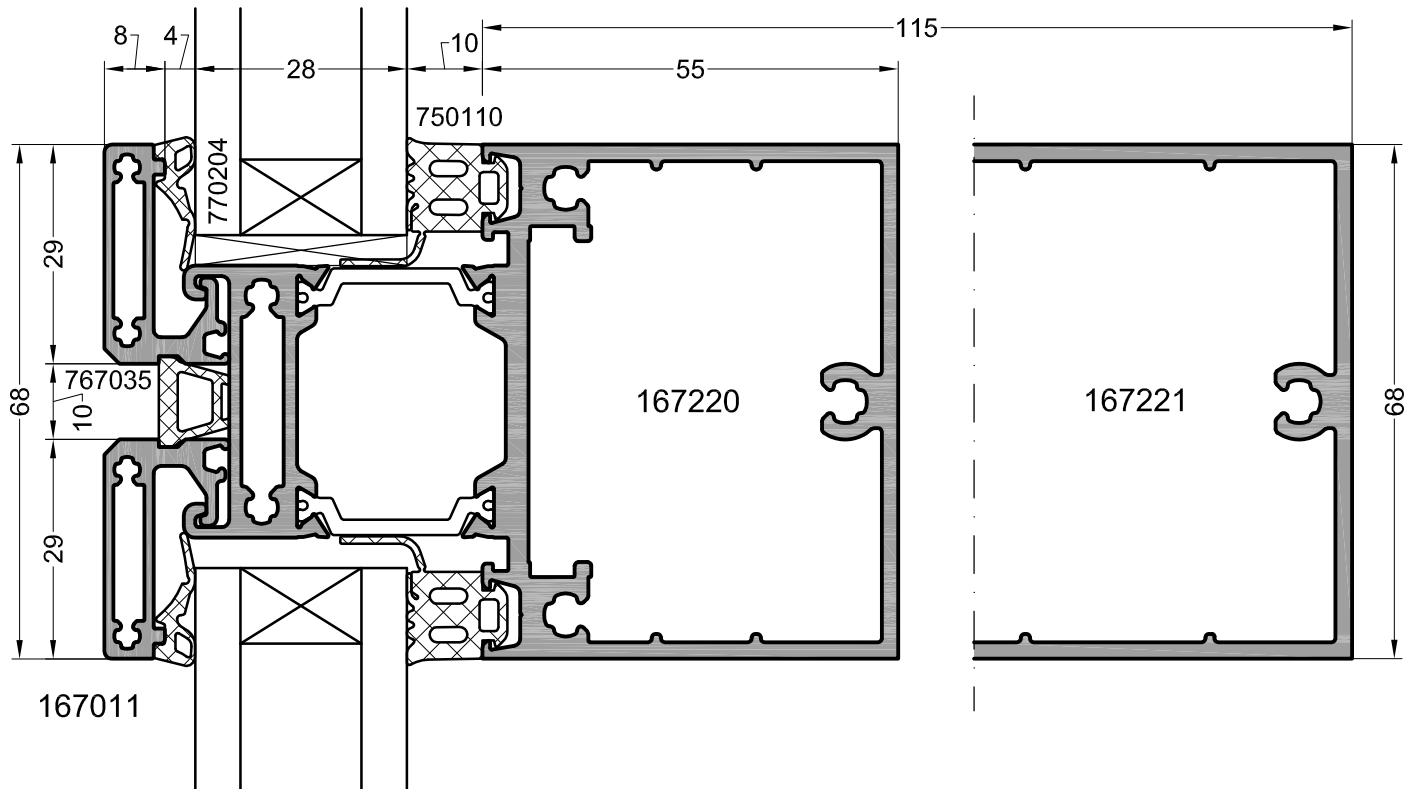
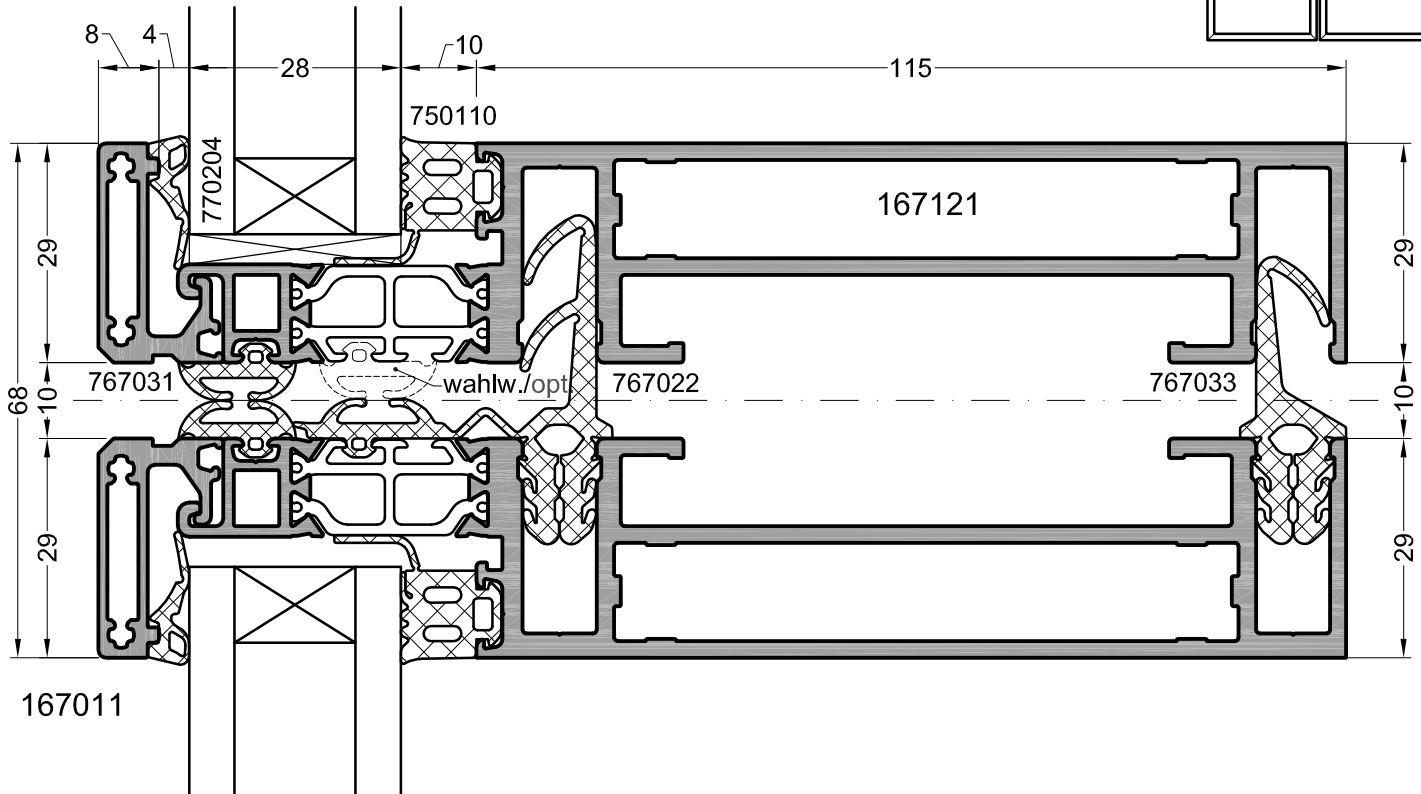

Pfosten senkrecht (Fuge - 20 mm, PA - Steg 26 mm)
Mullion, Vertical (gap 20 mm, PA bridge 26 mm)

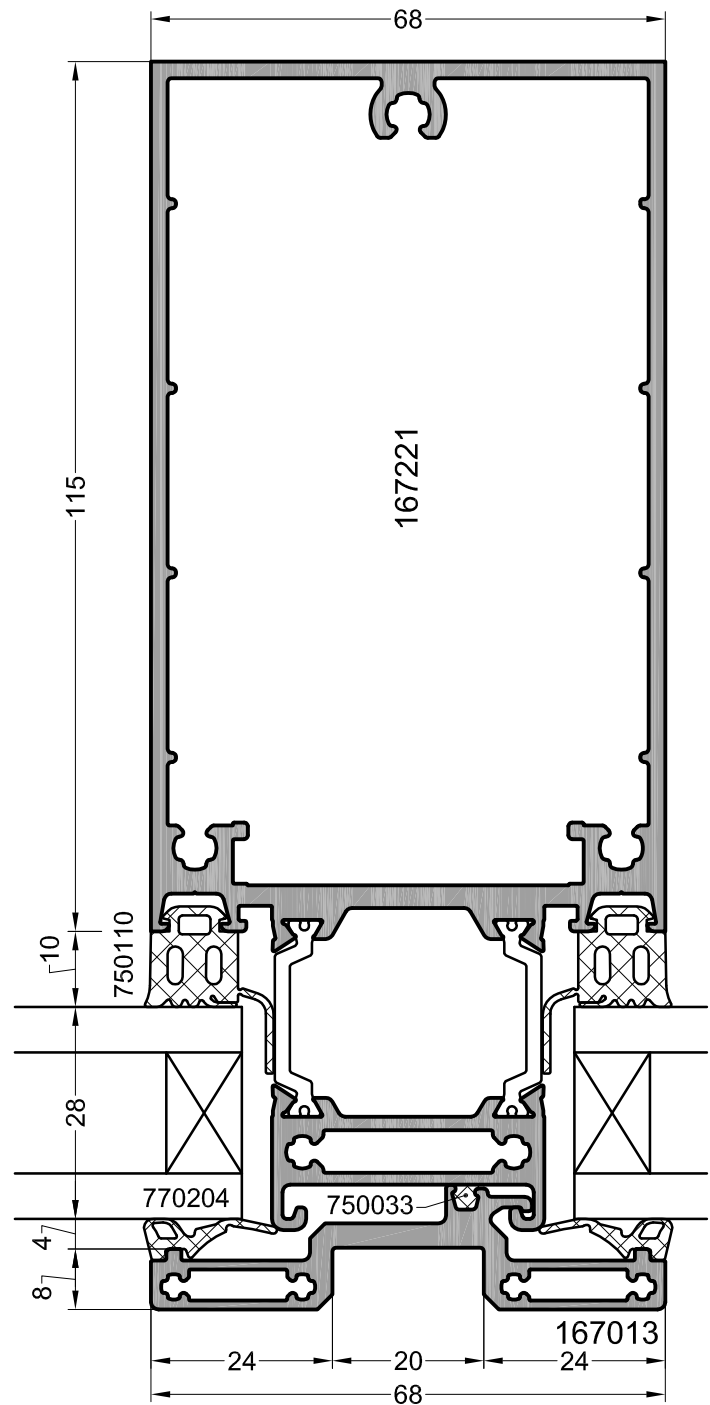
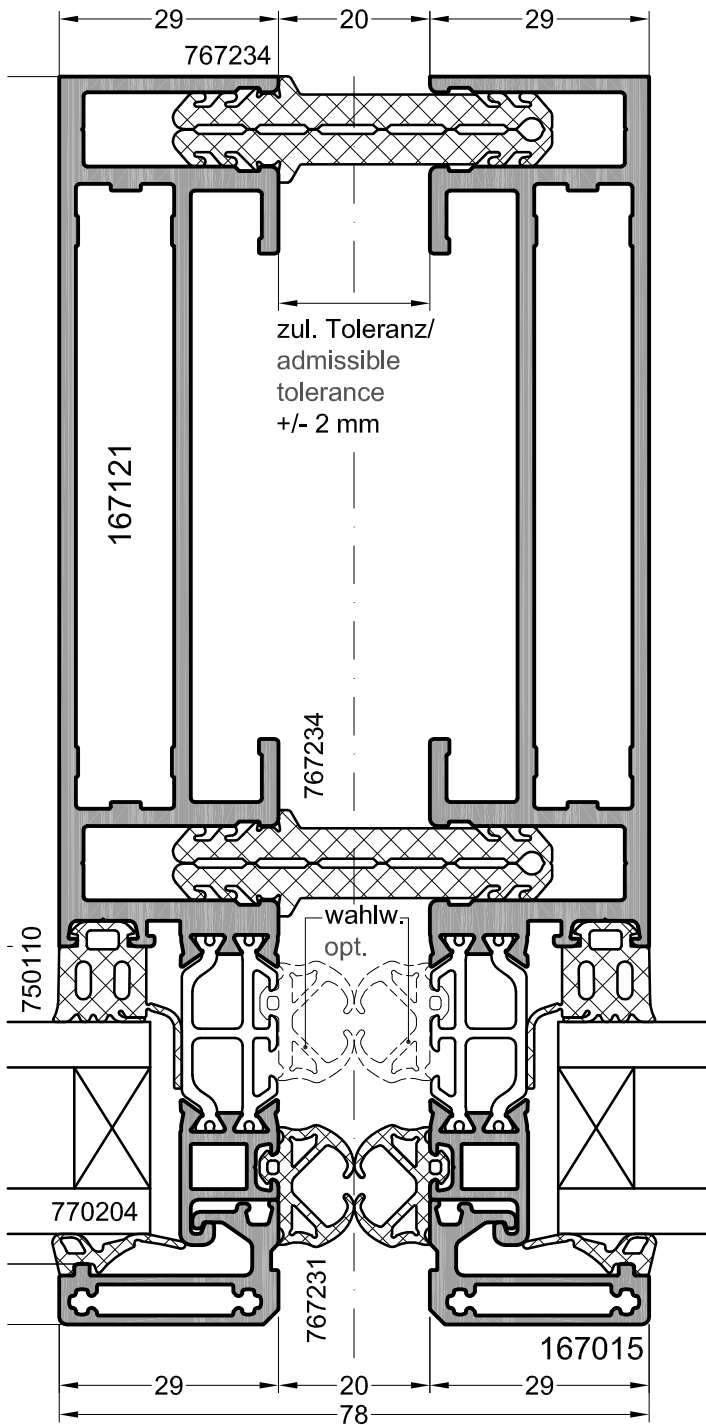
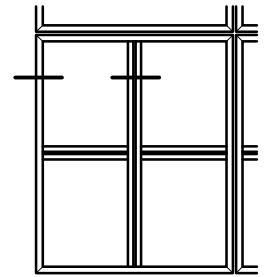

Riegel waagrecht (Fuge - 20 mm, PA - Steg 26 mm)/
Transom, horizontal (gap 20 mm, PA bridge 26 mm)

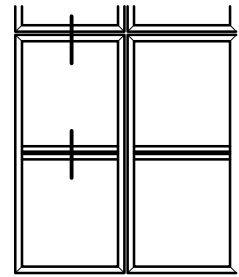

EF68
2

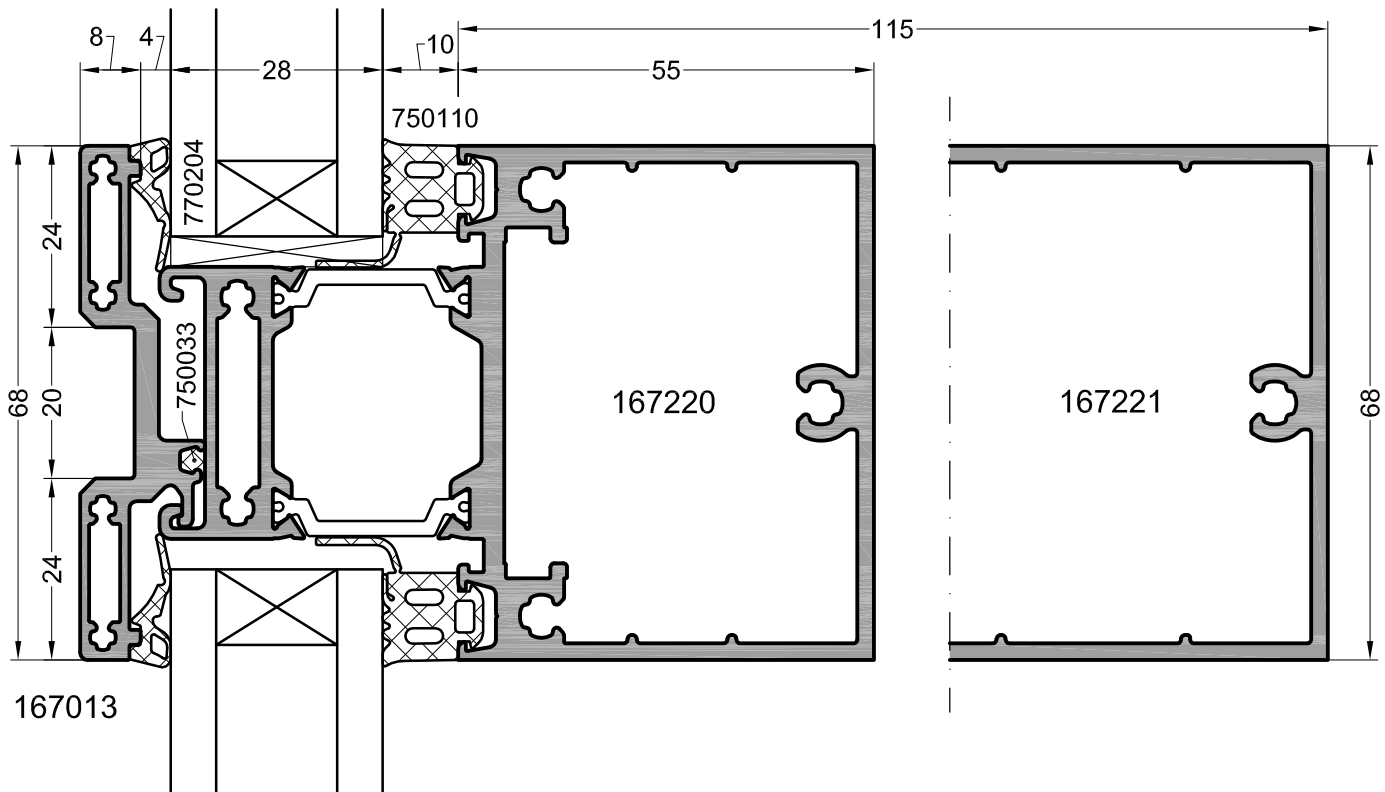
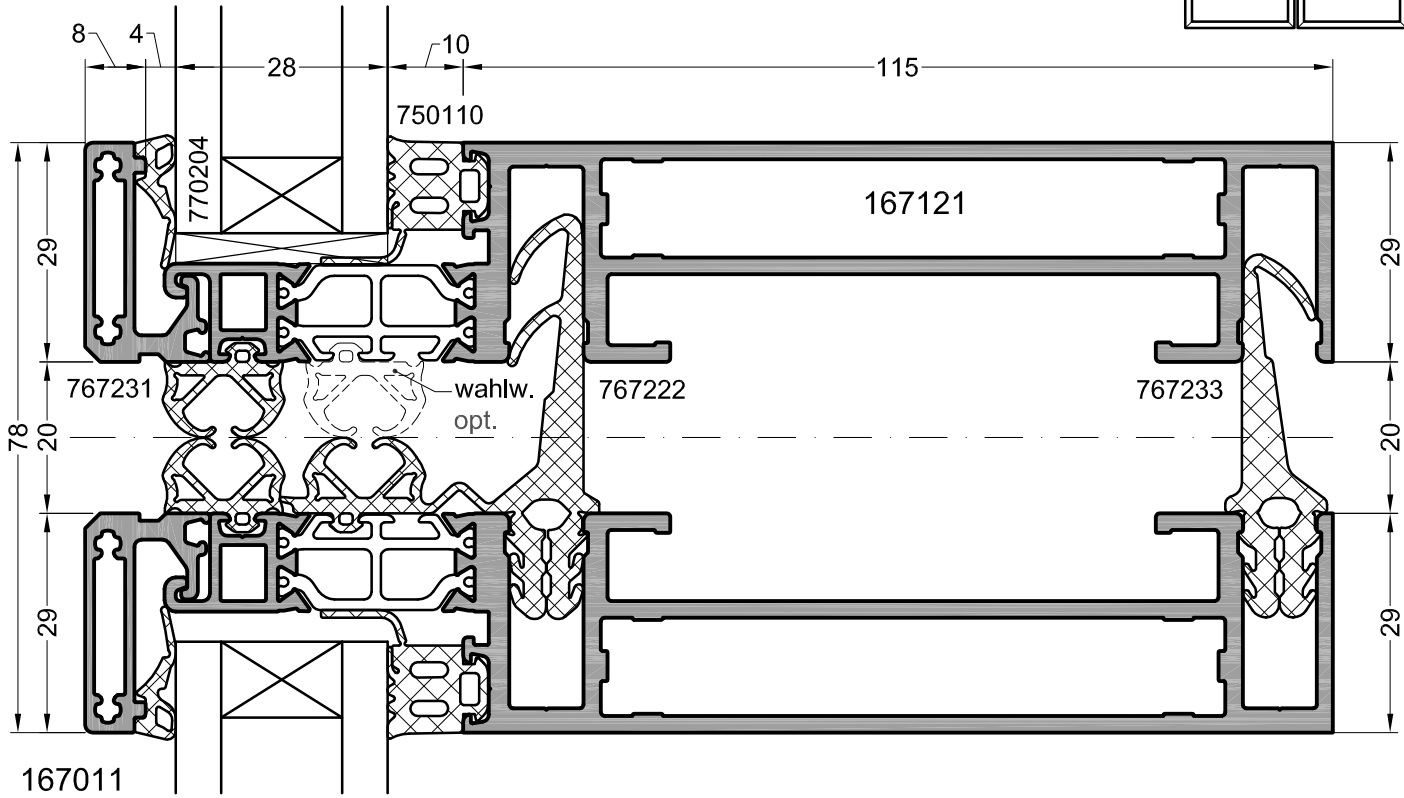



Pfosten senkrecht (Fuge - 10 mm, PA - Steg 26 mm)/
Mullion, Vertical (gap 10 mm, PA bridge 26 mm)
Optische SG - Fassade/
Simulated safety-glass curtain wall

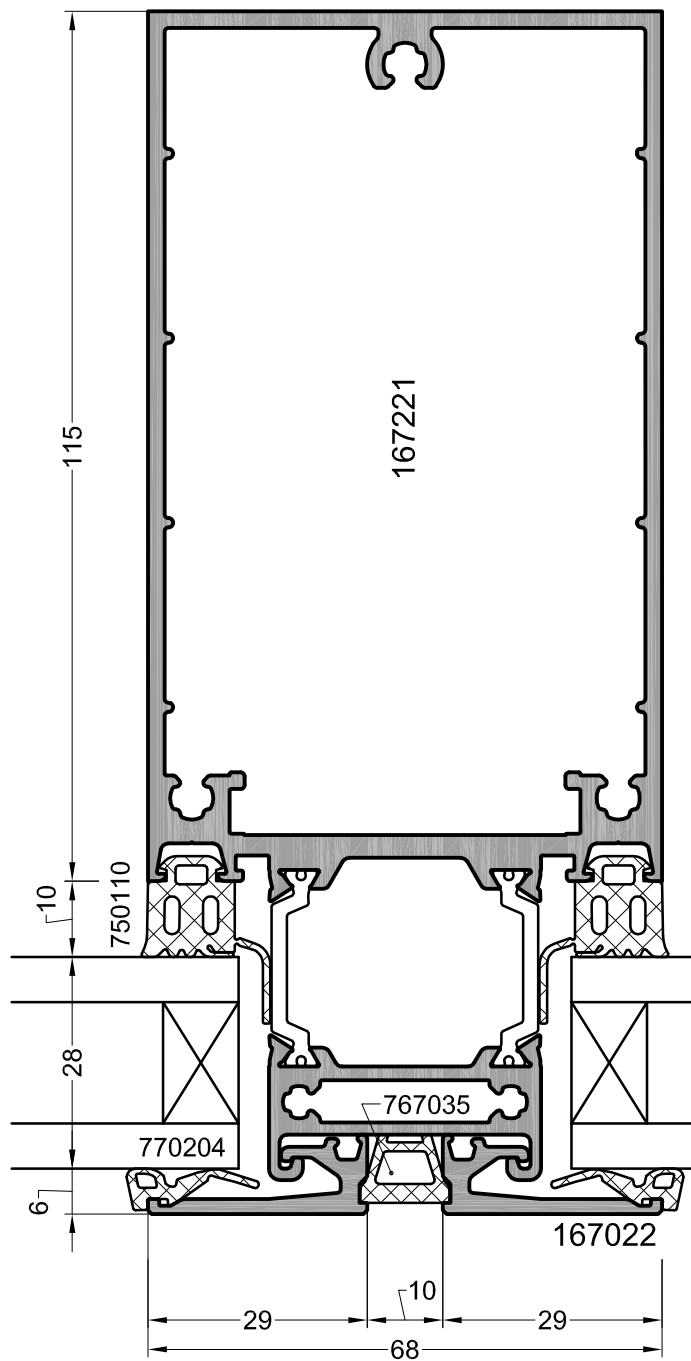
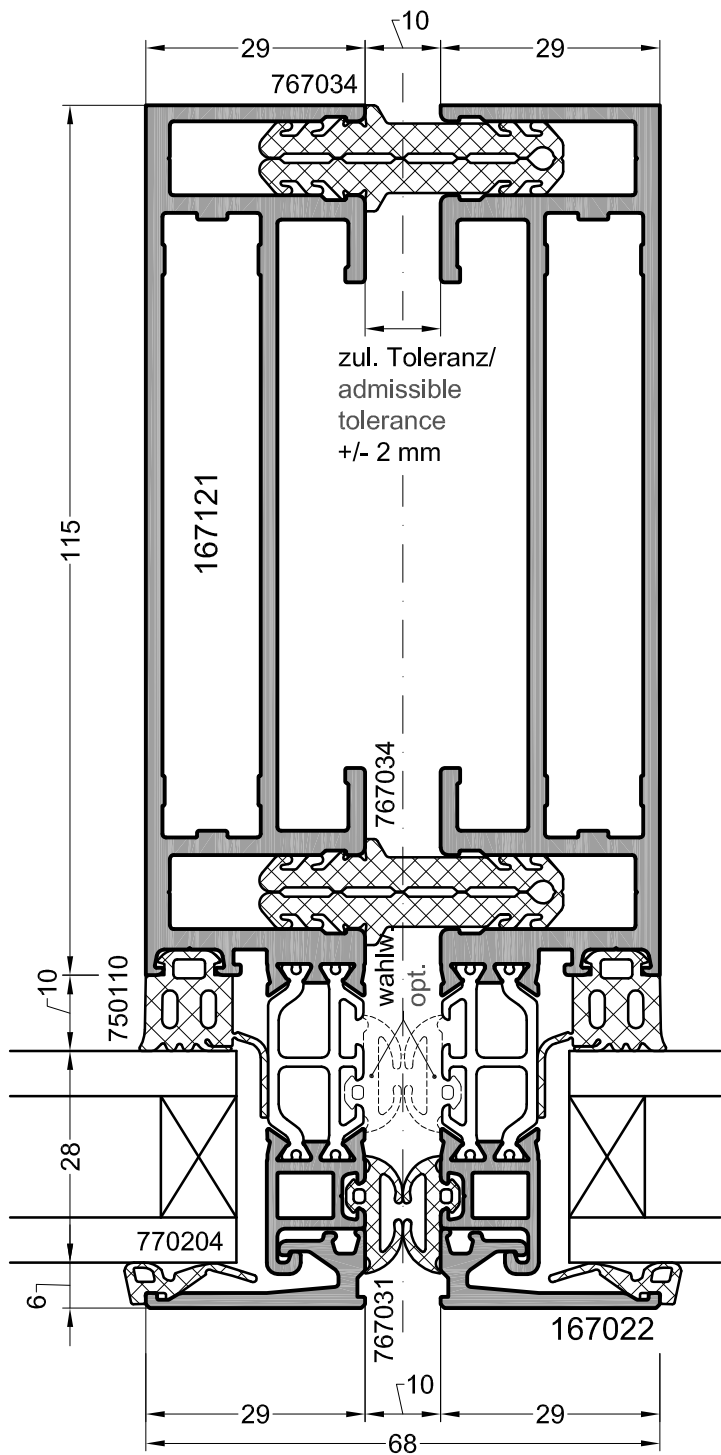
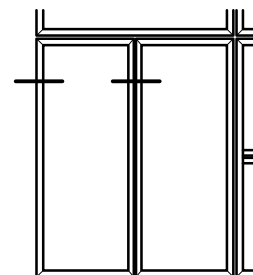

Riegel waagrecht (Fuge - 10 mm, PA - Steg 26 mm)/
Transom, horizontal (gap 10 mm, PA bridge 26 mm)
Optisch SG - Fassade/
Simulated safety-glass curtain wall

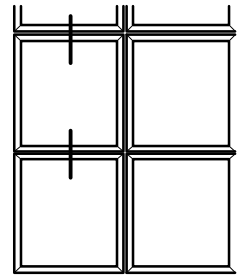

EF68 2

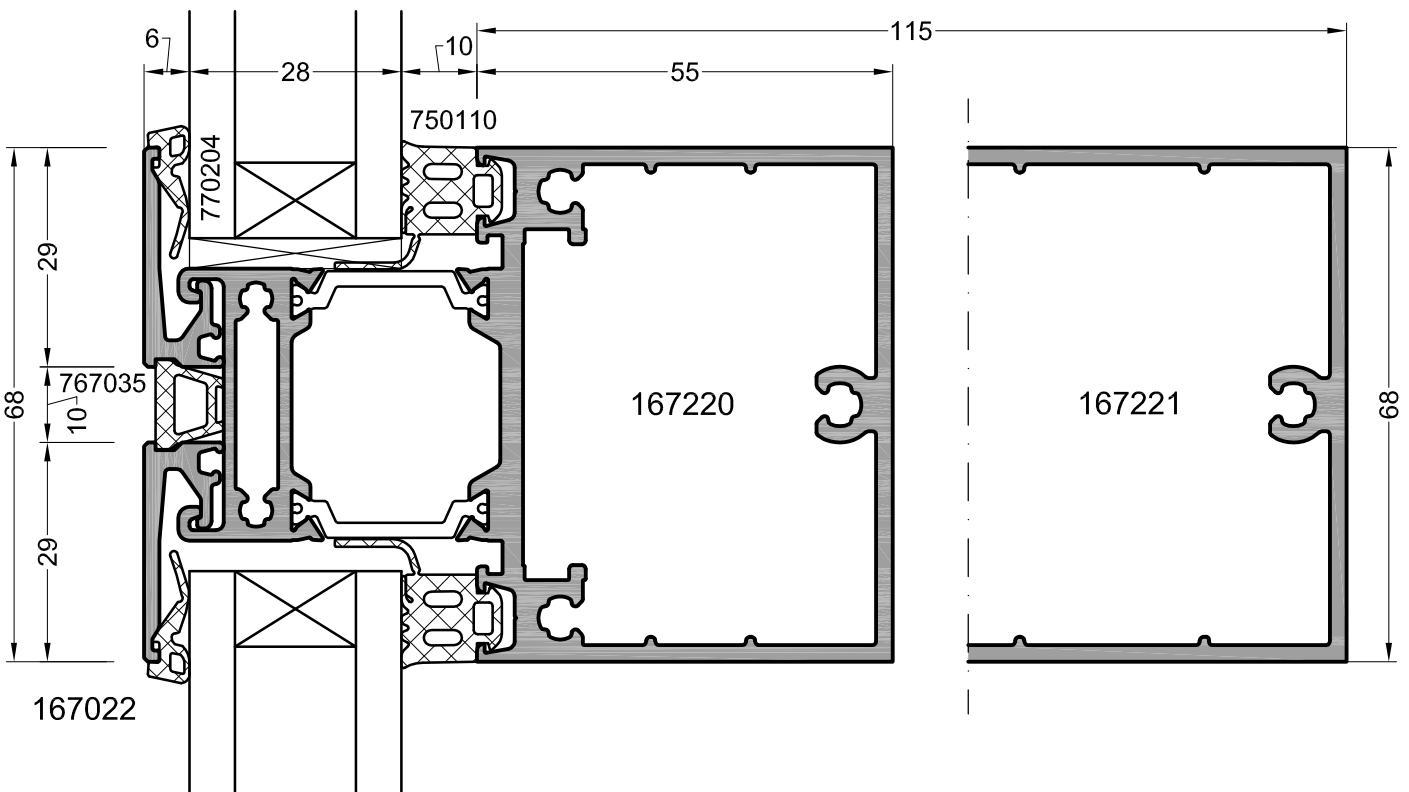
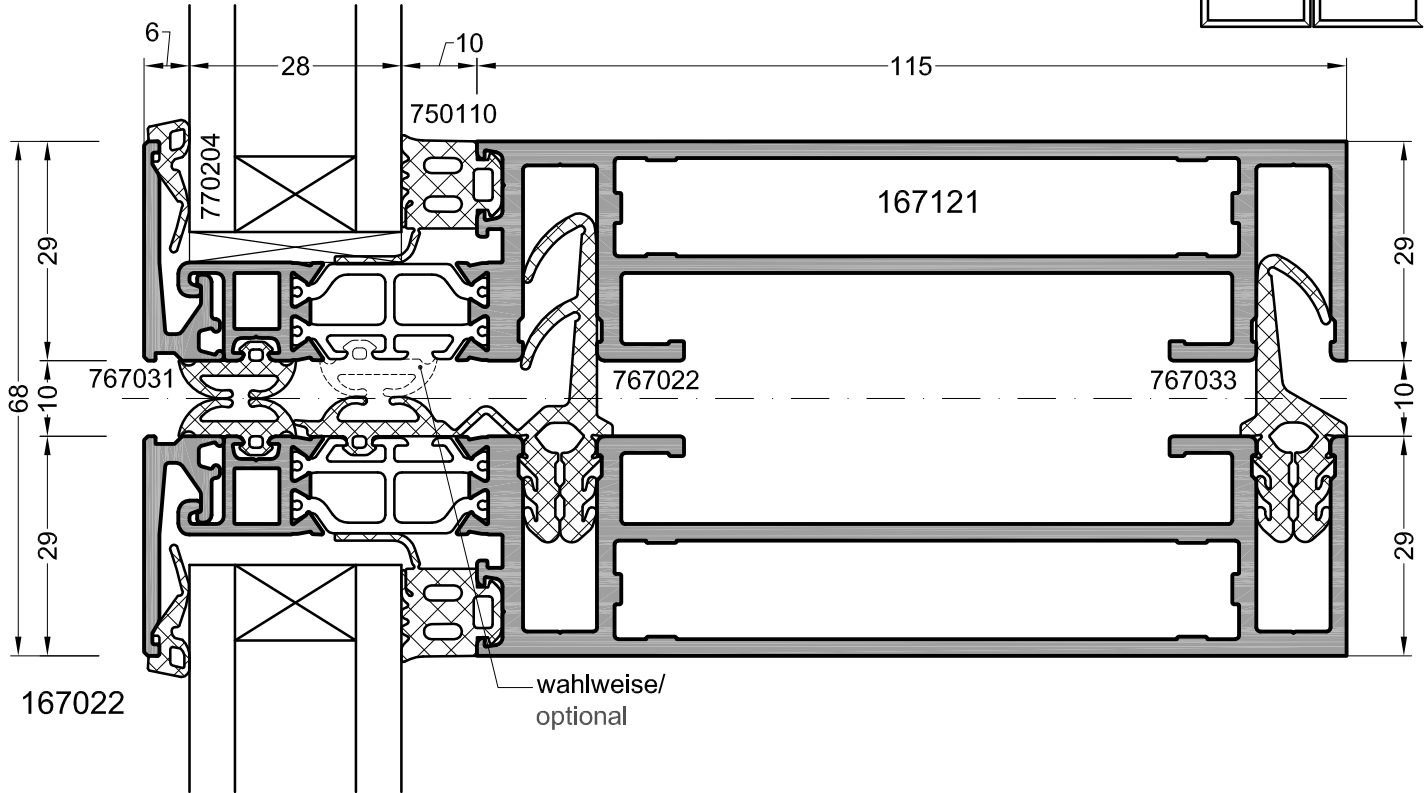

Pfosten senkrecht (Fuge 20 mm, PA - Steg 26 mm)
SG - Fassade (Export - Version)/
Mullion, Vertical (gap 20 mm, PA bridge 26 mm)
Safety-Glass Curtain Wall (export version)

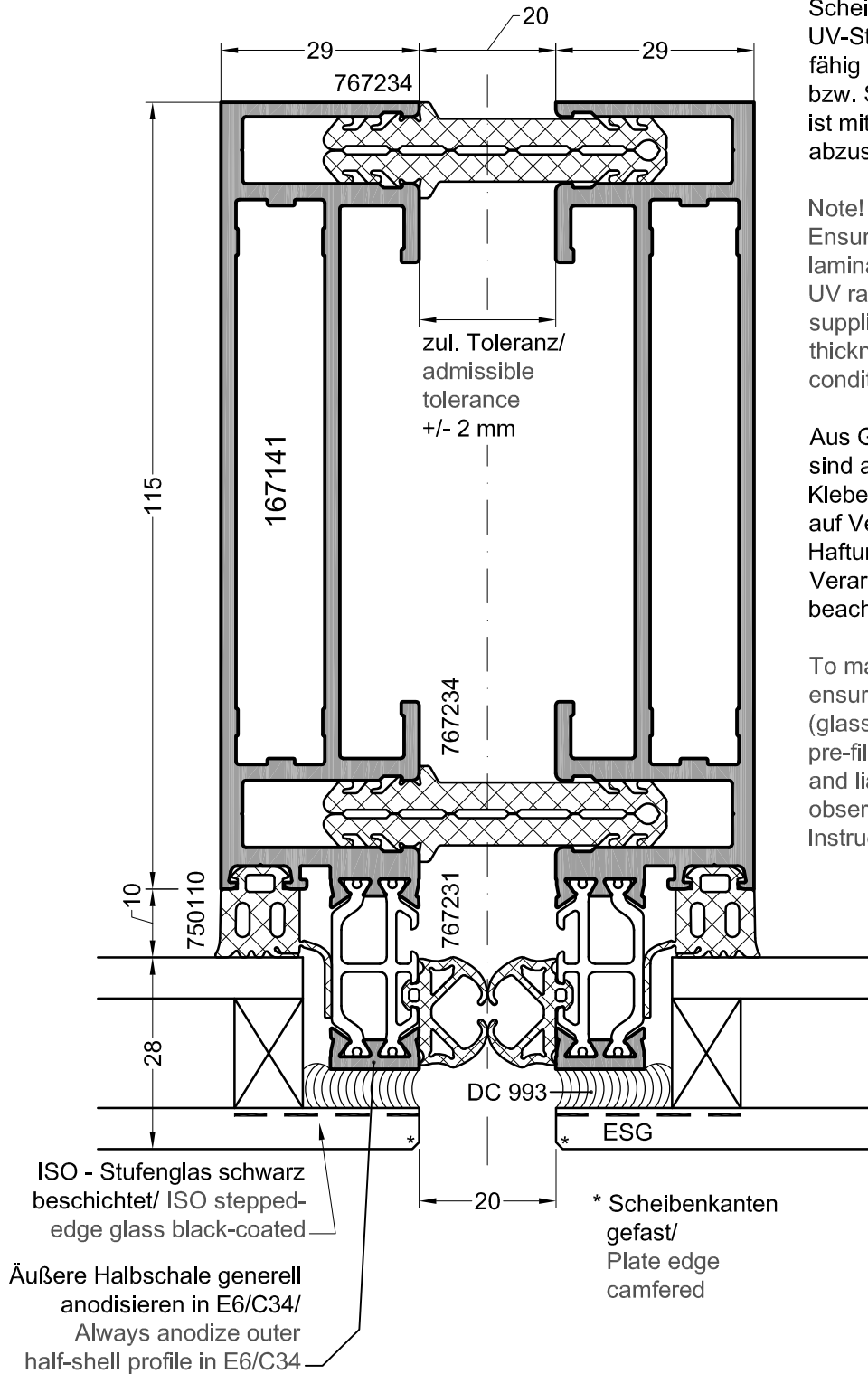
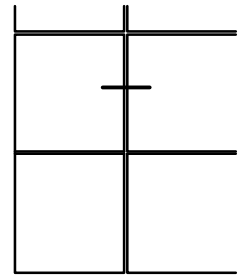

Achtung!
Scheibenrandverbund gegen UV-Strahlung widerstandsfähig ausführen. Glasdicken bzw. Scheibenrandausbildung ist mit dem Glaslieferanten abzustimmen.

Note!
Ensure that plate-edge lamination is resistant against UV radiation. Have glass supplier approve glass thicknesses and plate-edge conditions.

Aus Gewährleistungsgründen sind alle Komponenten (Glas, Kleber, Dichtmasse, Vorfüller) auf Verträglichkeit und Haftung abzustimmen und die Verarbeitungshinweise zu beachten.

To maintain the guarantee, ensure that all components (glass, glue, sealant, pre-filler) meet compatibility and liability requirements, and observe the Processing Instructions.

Riegel waagrecht (Fuge 20 mm, PA - Steg 26 mm)/
Transom, horizontal (gap 20 mm, polyamide bridge 26 mm)
SG - Fassade (Export - Version)/
Safety-Glass Glazing Curtain Wall (export version)

Achtung!/ Note!

Scheibenrandverbund gegen UV-Strahlung widerstandsfähig ausführen. Glasdicken bzw. Scheibenrandausbildung ist mit dem Glaslieferanten abzustimmen./ Ensure that plate-edge lamination is resistant against UV radiation. Have glass supplier approve glass thicknesses and plate-edge conditions.

Aus Gewährleistungsgründen sind alle Komponenten (Glas, Kleber, Dichtmasse, Vorfüller) auf Verträglichkeit und Haftung abzustimmen und die Verarbeitungshinweise zu beachten./

To maintain the guarantee, ensure that all components (glass, glue, sealant, pre-filler) meet compatibility and liability requirements, and observe the Processing Instructions.

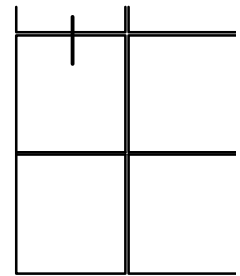

EF68
2

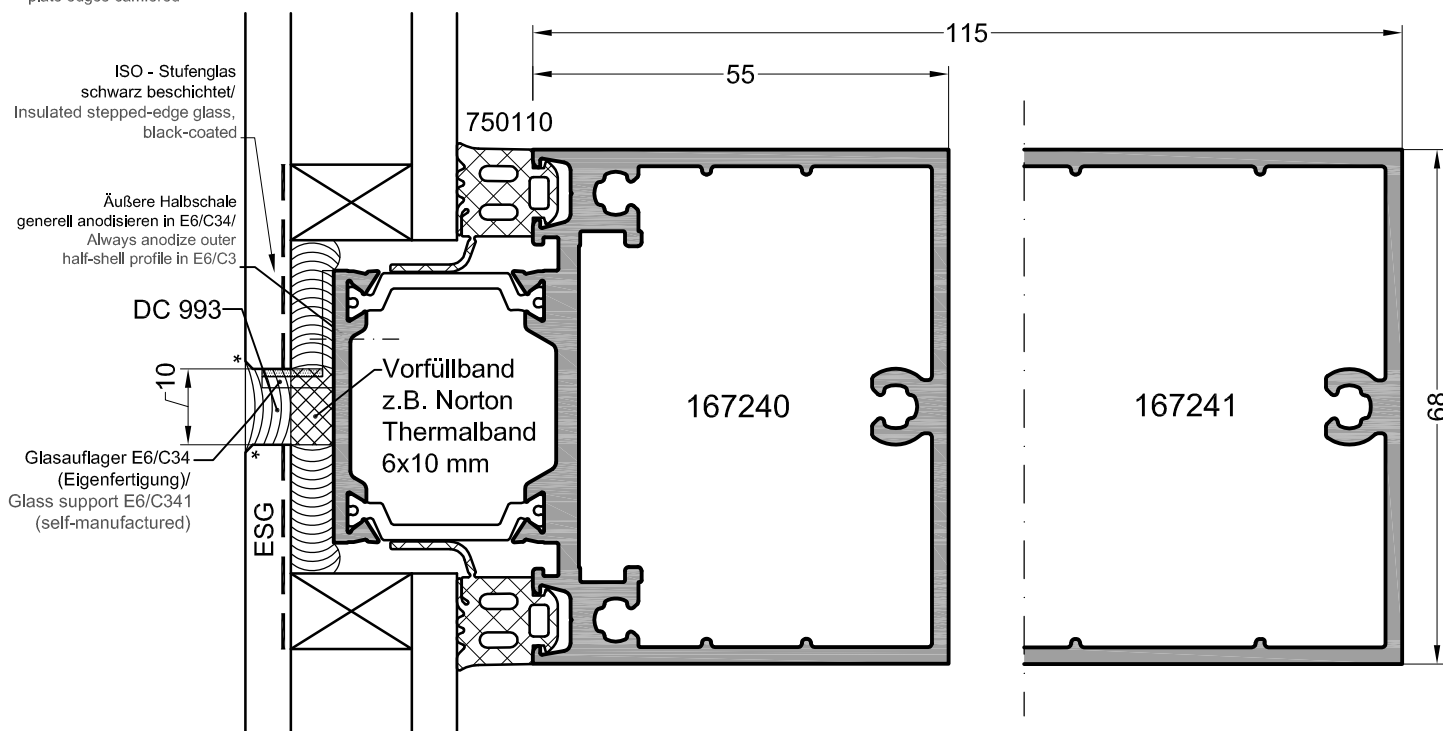
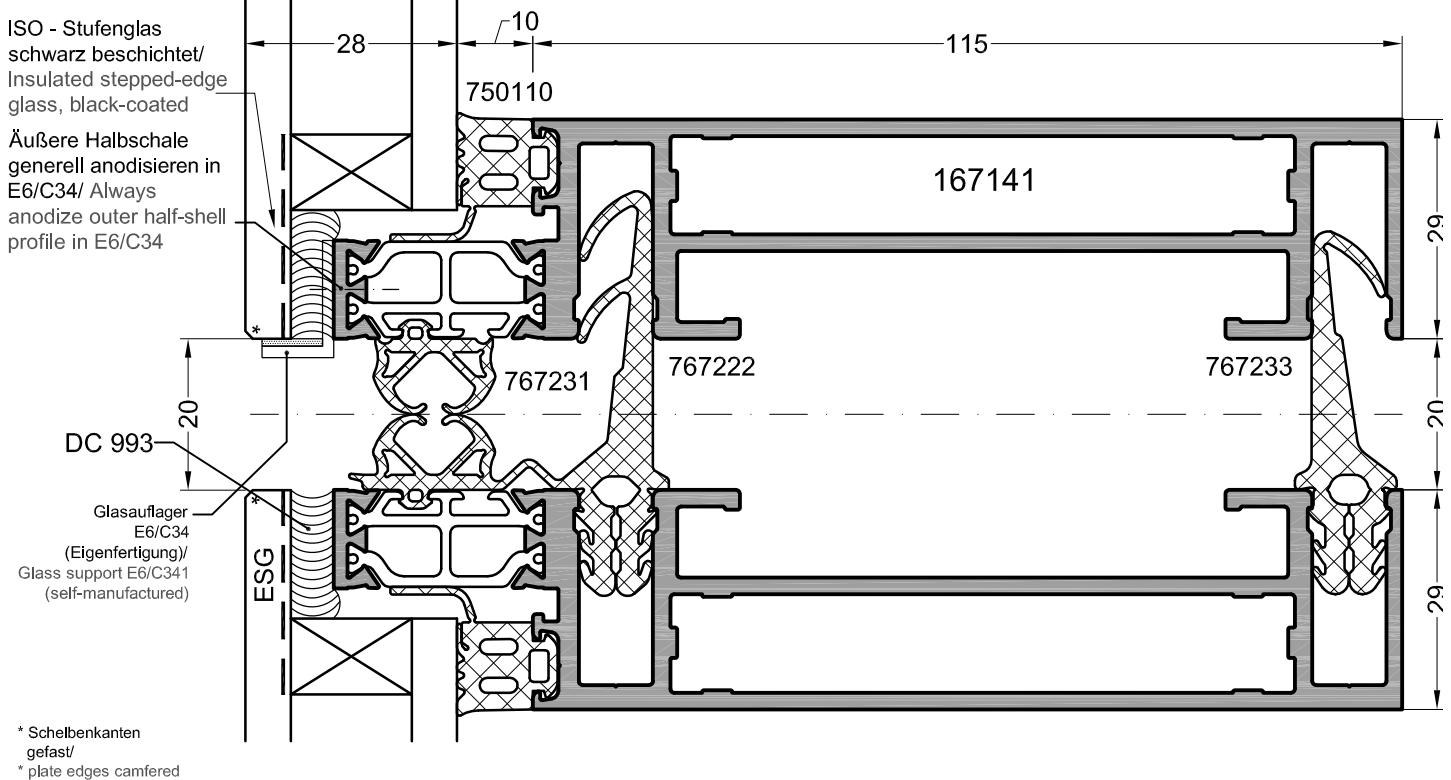

Elementstoß Zwischendecke/ Element Joint for Suspended Ceiling

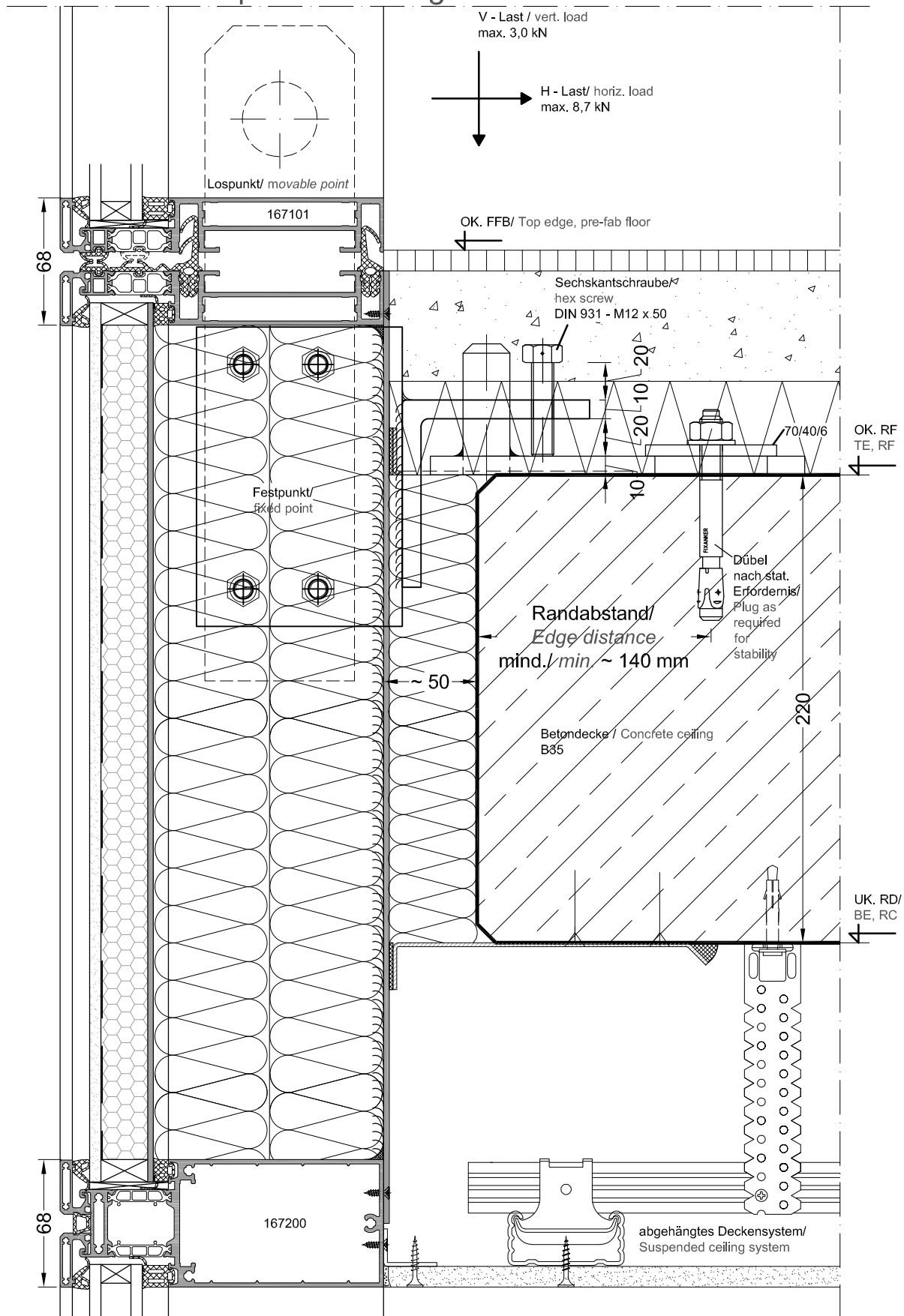

Elementstoß Zwischendecke/ Element Joint for Suspended Ceiling

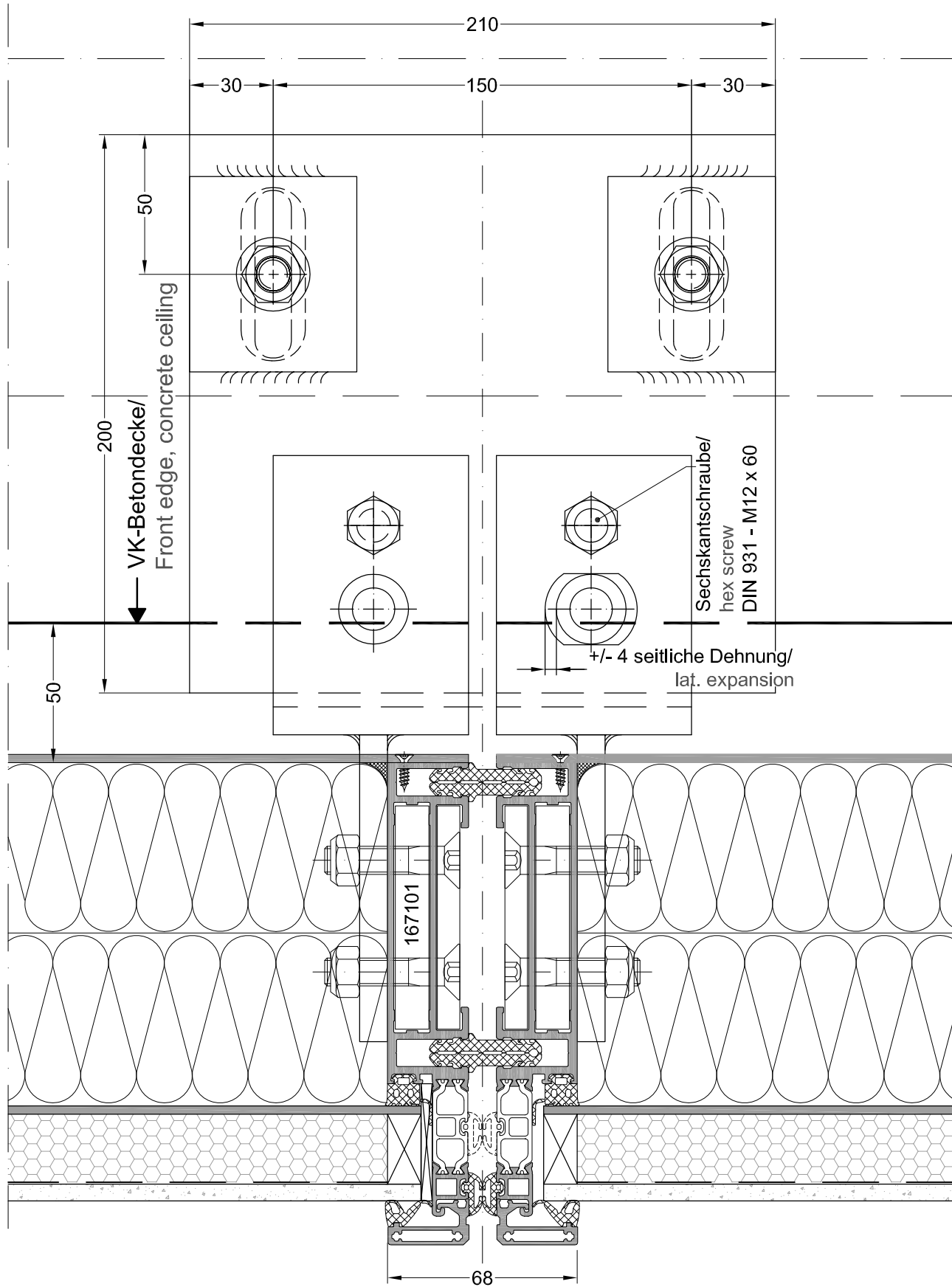

EF68
2

Detail Fußpunkt/
Detail, Base Point

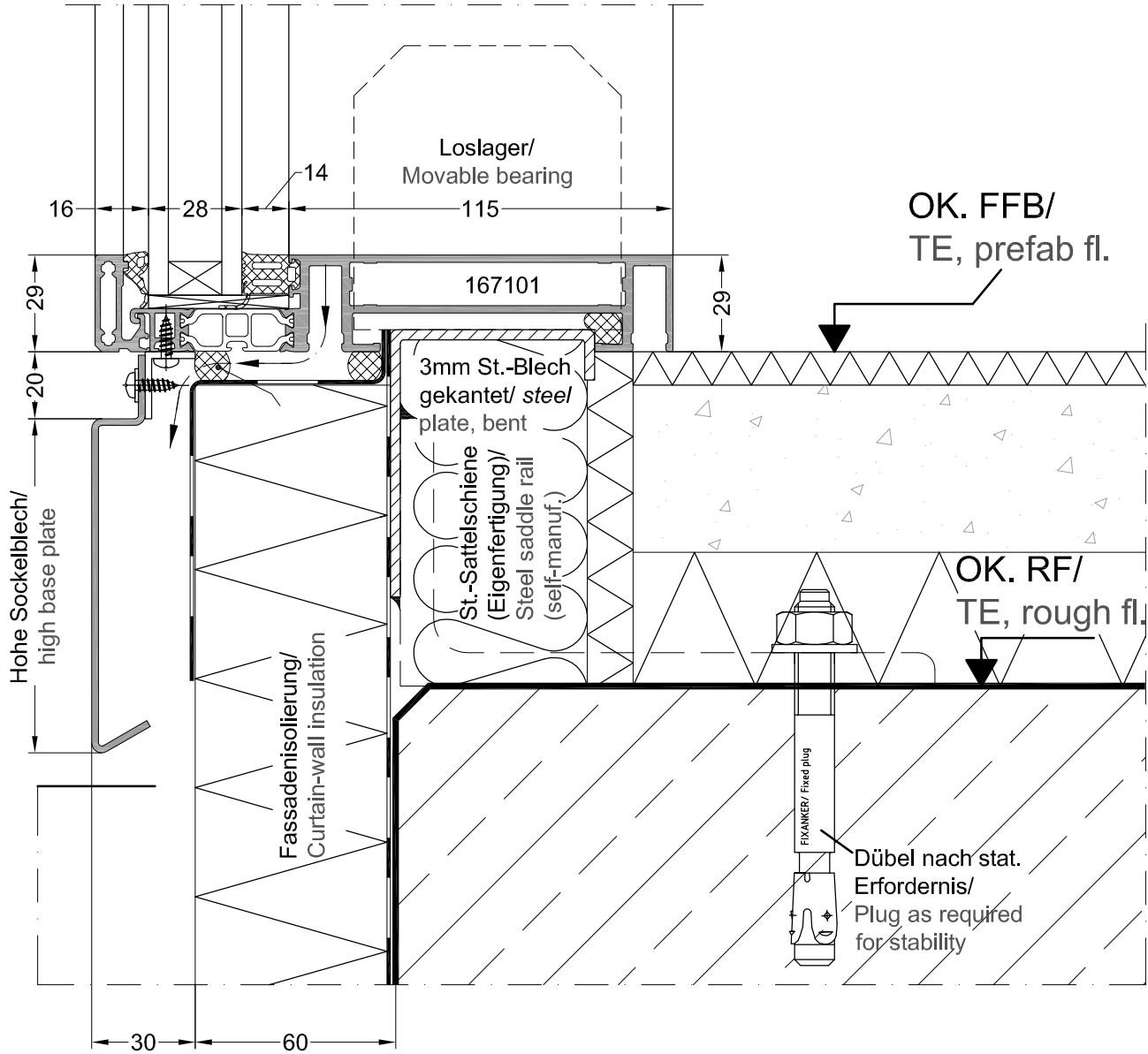

**Detail 90° Außenecke (Ganzglasecke)/
Detail 90°, outer corner (all-glass corner)**



Achtung!/ Note!
Scheibenrandverbund gegen UV - Strahlung widerstandsfähig ausführen.
Glasdicken bzw. Scheibenrandausbildung ist mit dem Glaslieferanten abzustimmen/
Ensure that plate-edge lamination is resistant against UV radiation. Have glass supplier approve glass thicknesses and plate-edge conditions.

Aus Gewährleistungsgründen sind alle Komponenten (Glas, Kleber, Dichtmasse, Vorfüller) auf Verträglichkeit und Haftung abzustimmen und die Verarbeitungshinweise zu beachten/
To maintain the guarantee, ensure that all components (glass, glue, sealant, pre-filler) meet compatibility and liability requirements, and observe the Processing Instructions.

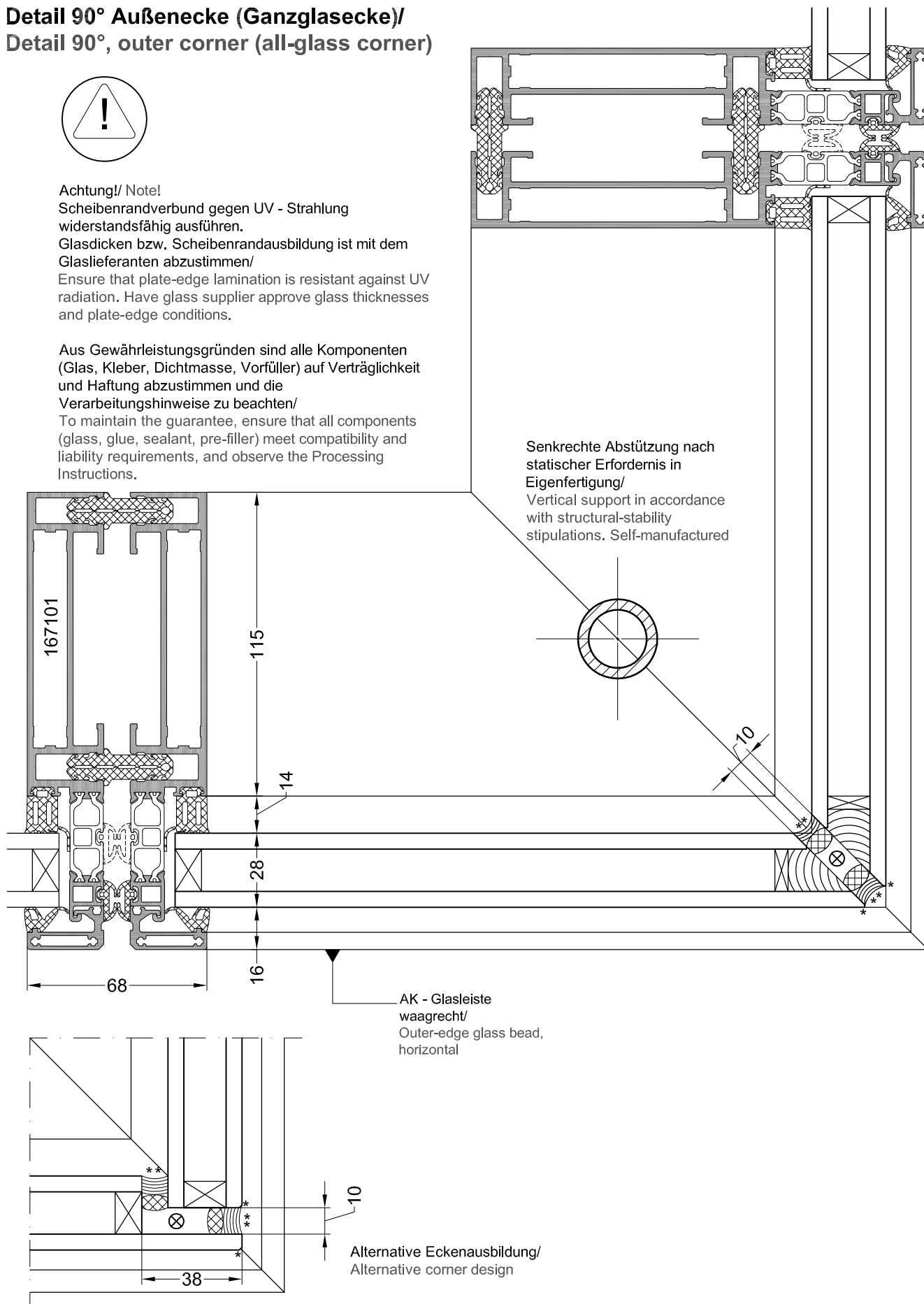

EF68
2

Detail 90° Innenecke(Ganzglasecke)/ Detail 90°, outer corner (all-glass corner)

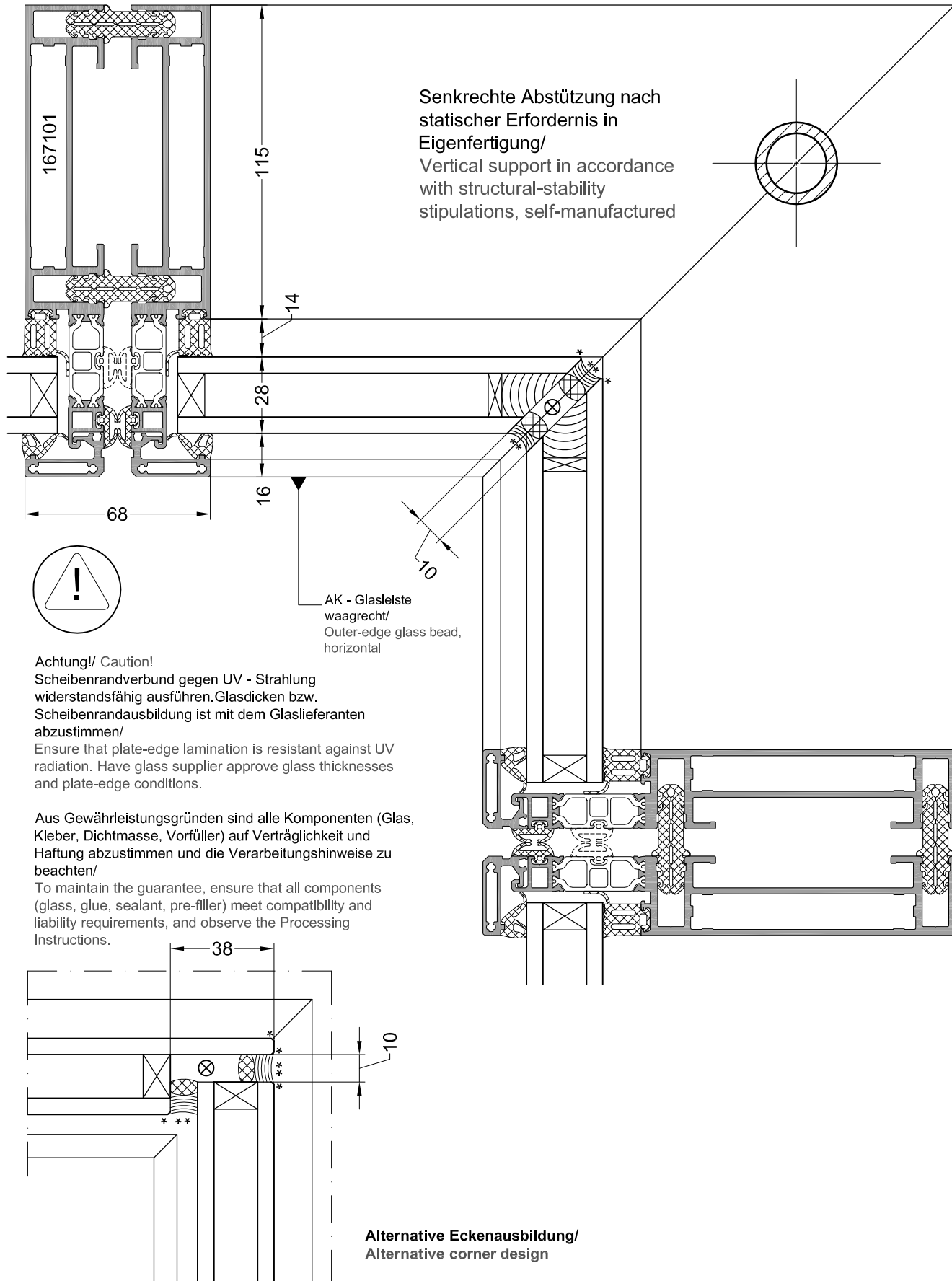

Pfosten senkrecht (Fuge - 10 mm, PA - Steg 34 mm)
mit DK - Einsatzfenster

Mullion, Vertical (gap 10 mm, PA bridge 34 mm)
with T&T Panel Window

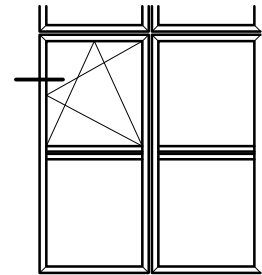

EF68 2

